

Vehicle Information	
Year	2023
Make	Ford
Model	F150

Enclosure Information	
Design Type	Bass-Reflex
Placement	Under Seat
Orientation	Position the enclosure with the subs directed forward, vent directed toward the passenger side.



**AUDIO DYNAMICS**

Special Notes

Amplifier Information	
Continuous Power Handling	2,400 W
Subsonic Filter Setting	28 Hz
Low Pass Filter Setting	48 Hz

Subwoofer Information	
Make	Audio Dynamics
Model	AD3008 D2
Quantity	4

Performance Information	
SQ	<input checked="" type="checkbox"/> Within the Vehicle
<input checked="" type="checkbox"/> SQL	Outside the Vehicle
SPL	Metering Position

Metering Information		
Headrest	Peak Frequency	Hz
Dash / Windshield		
Foot Well		

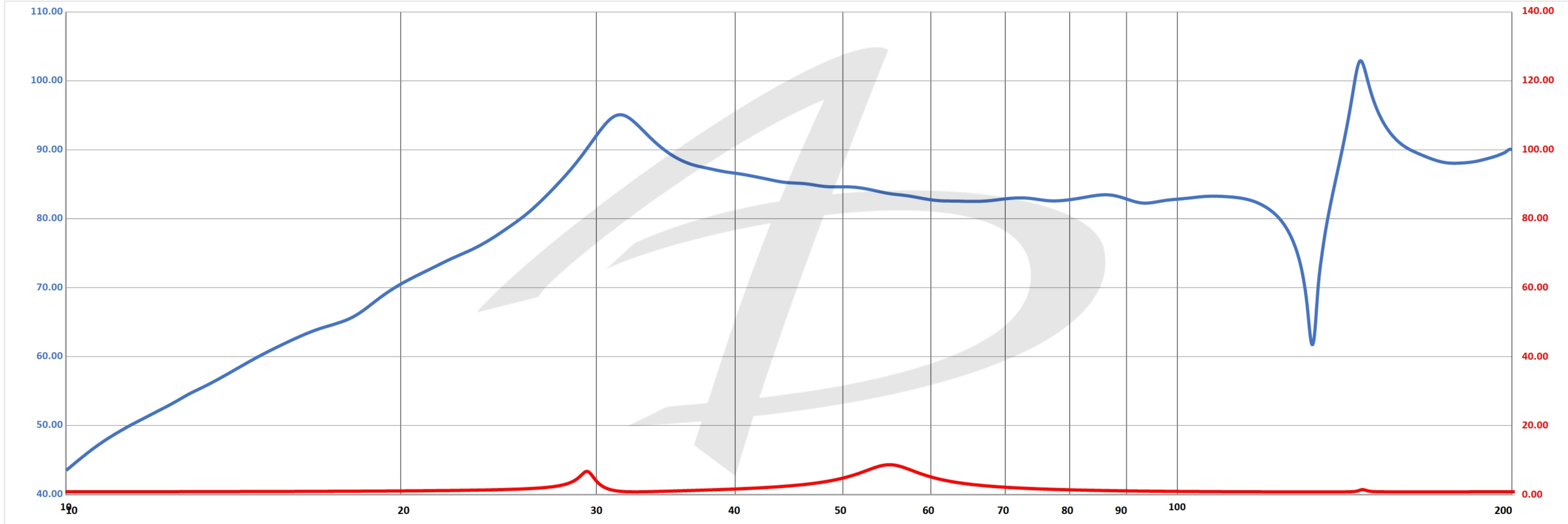

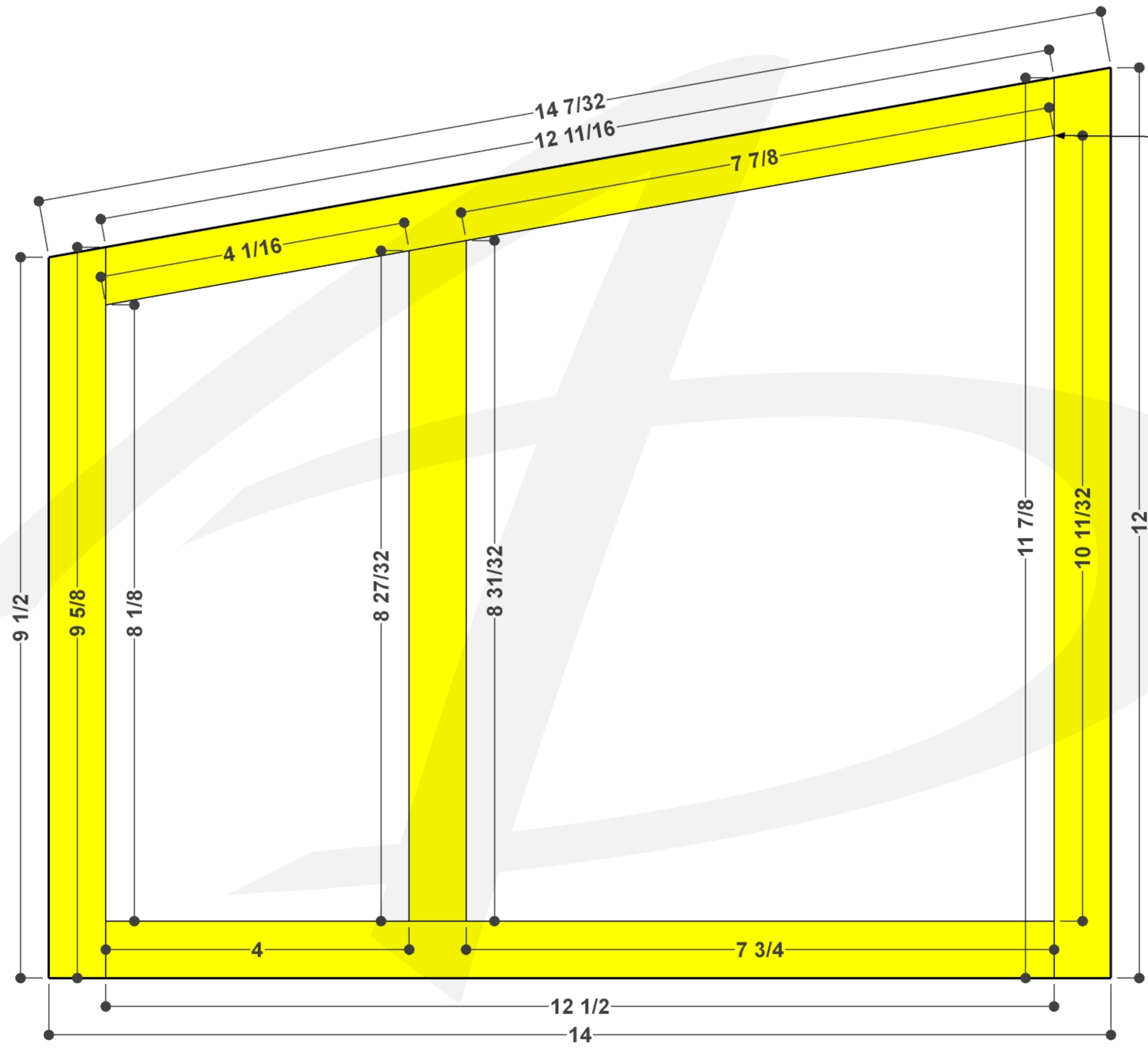

Use a 10.1 deg. blade tilt setting for all the non-90 deg. angles associated with the slant.

The width of all the panels, except the vent panel should be 38 1/2". The vent panel, highlighted in yellow, should be 34 1/2" wide, and flush with the passenger side.

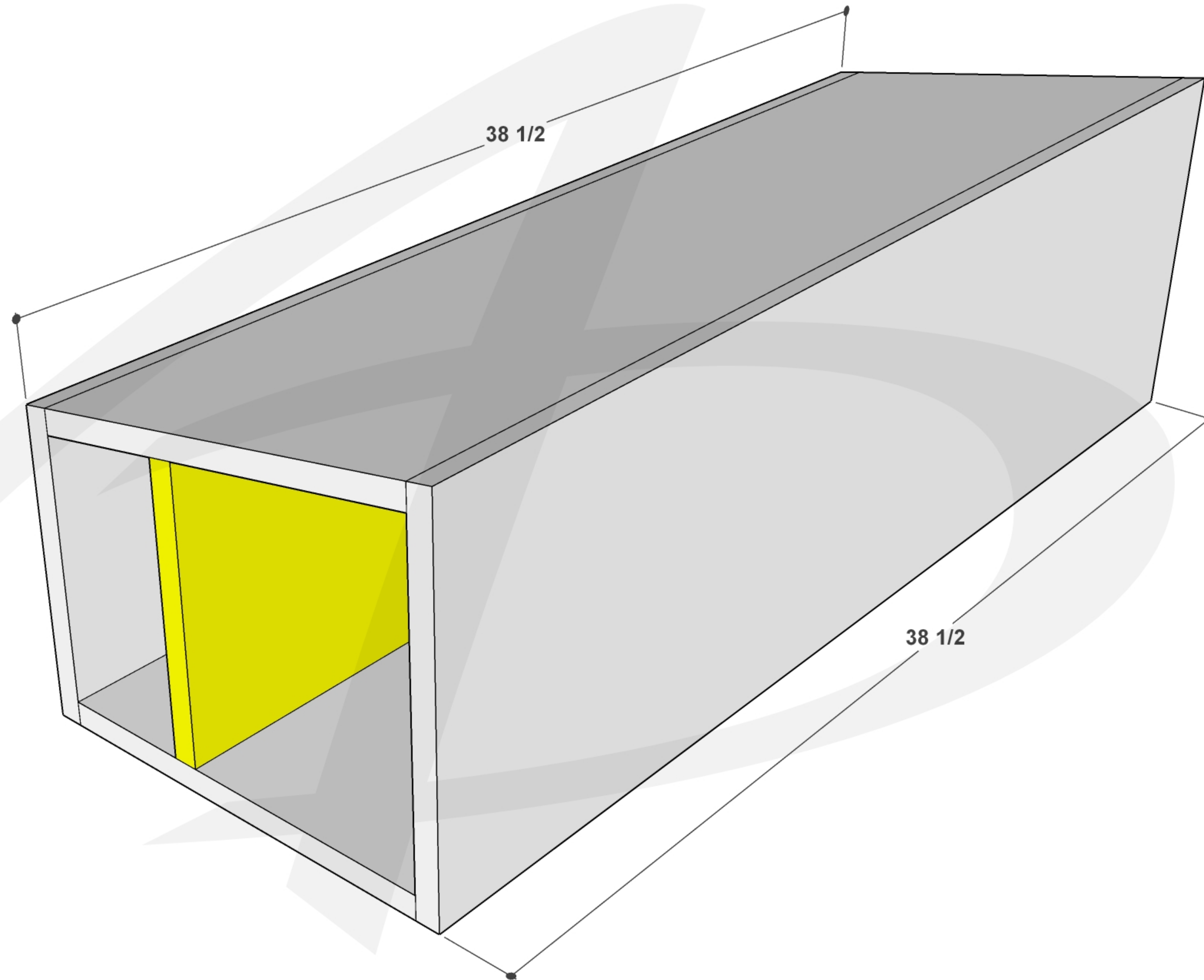

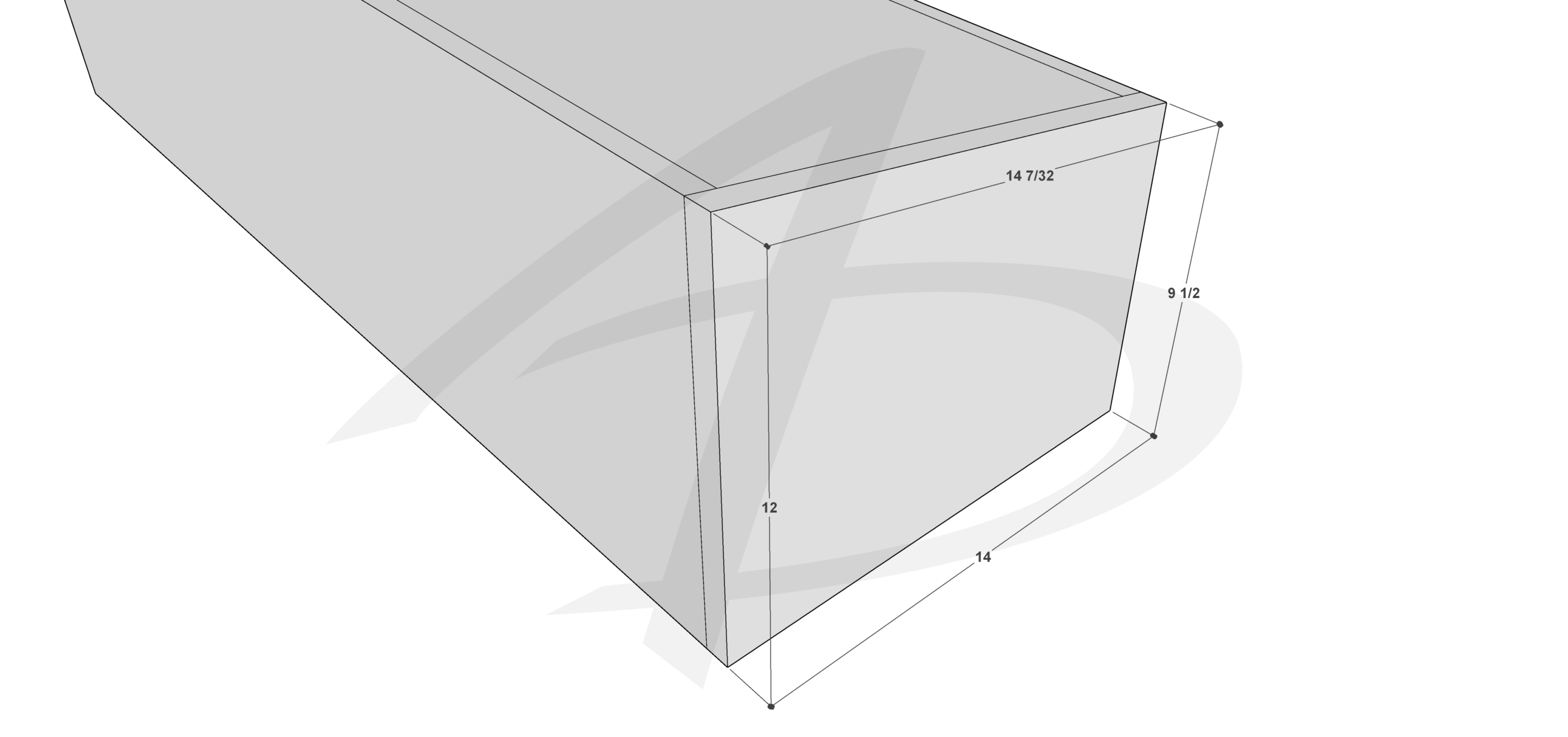

14 7/32

9 1/2

12

14

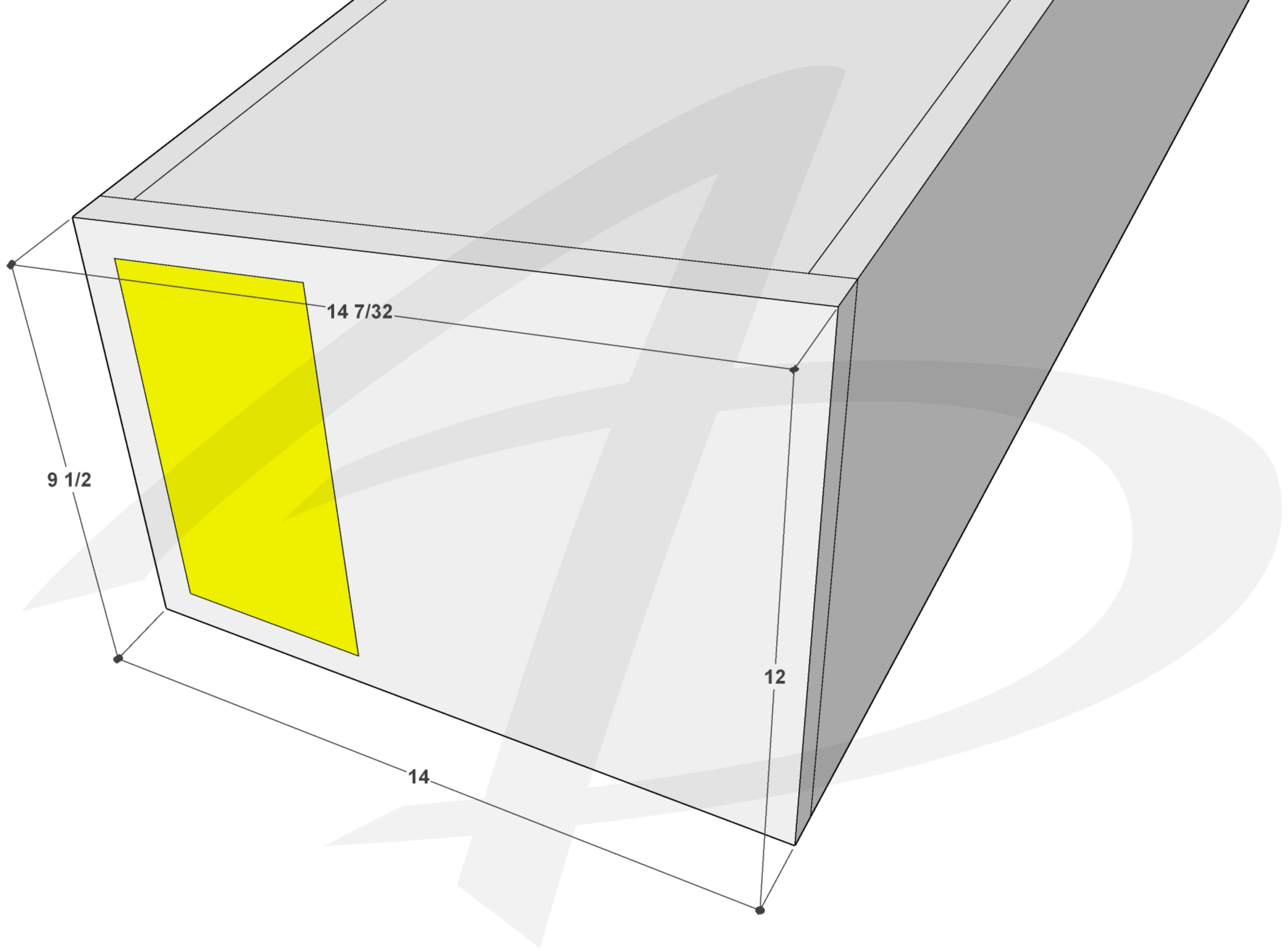

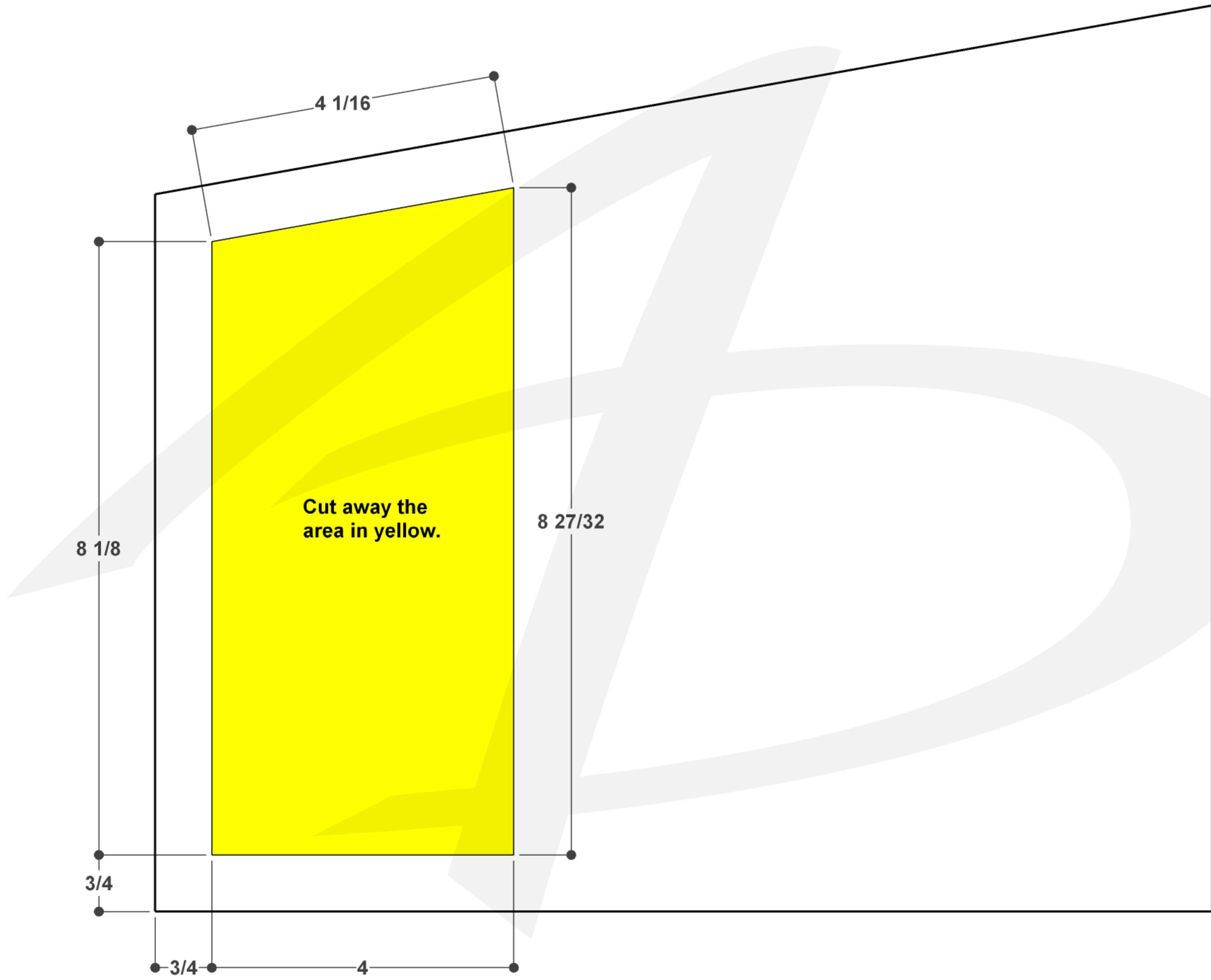

$8 \frac{1}{8}$

$4 \frac{1}{16}$

$8 \frac{27}{32}$

$\frac{3}{4}$

$\frac{3}{4}$

4

Cut away the  
area in yellow.

