

Vehicle Information	
Year	2022
Make	Ford
Model	Bronco

Enclosure Information	
Design Type	Bass-Reflex
Placement	Cargo area
Orientation	Position the enclosure with the subs directed upward, vents directed rearward.



AUDIO DYNAMICS

Special Notes	
Flare the outer vent openings as they will be prone to chuffing at volume.	

Amplifier Information	
Continuous Power Handling	3,000 W
Subsonic Filter Setting	24 Hz
Low Pass Filter Setting	55 Hz

Subwoofer Information	
Make	Audio Dynamics
Model	AD4212 D4
Quantity	2

Performance Information	
SQ	<input checked="" type="checkbox"/> Within the Vehicle
<input checked="" type="checkbox"/> SQL	Outside the Vehicle
SPL	Metering Position

Metering Information		
Headrest	Peak Frequency	Hz
Dash / Windshield		
Foot Well		

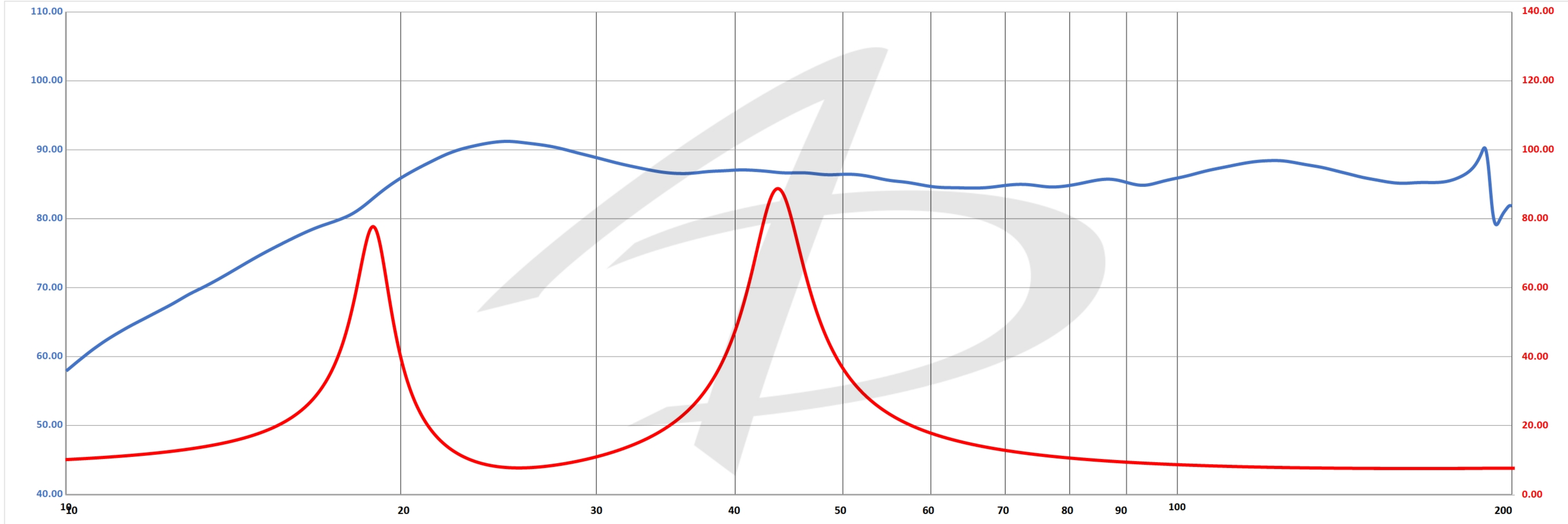

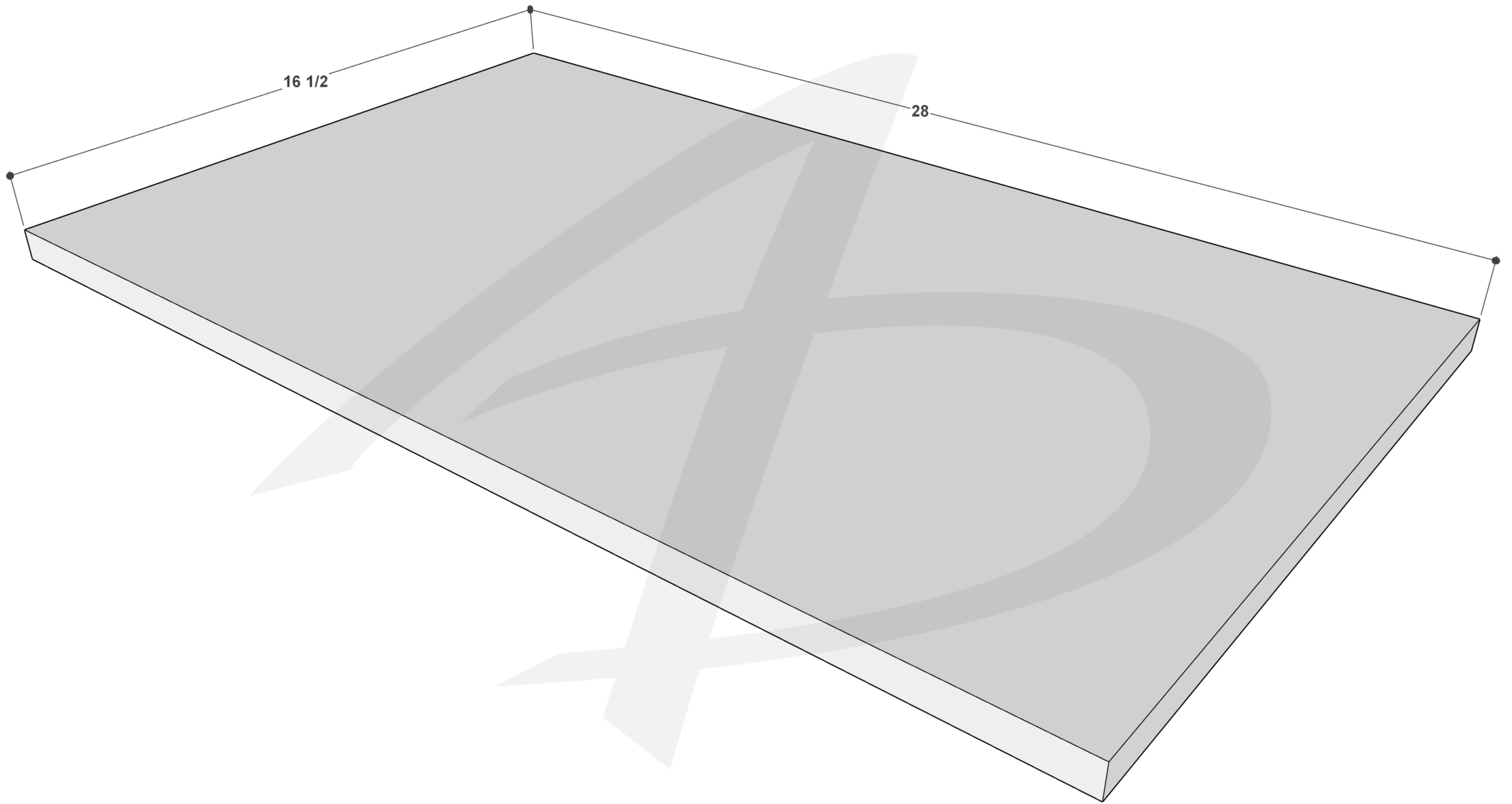

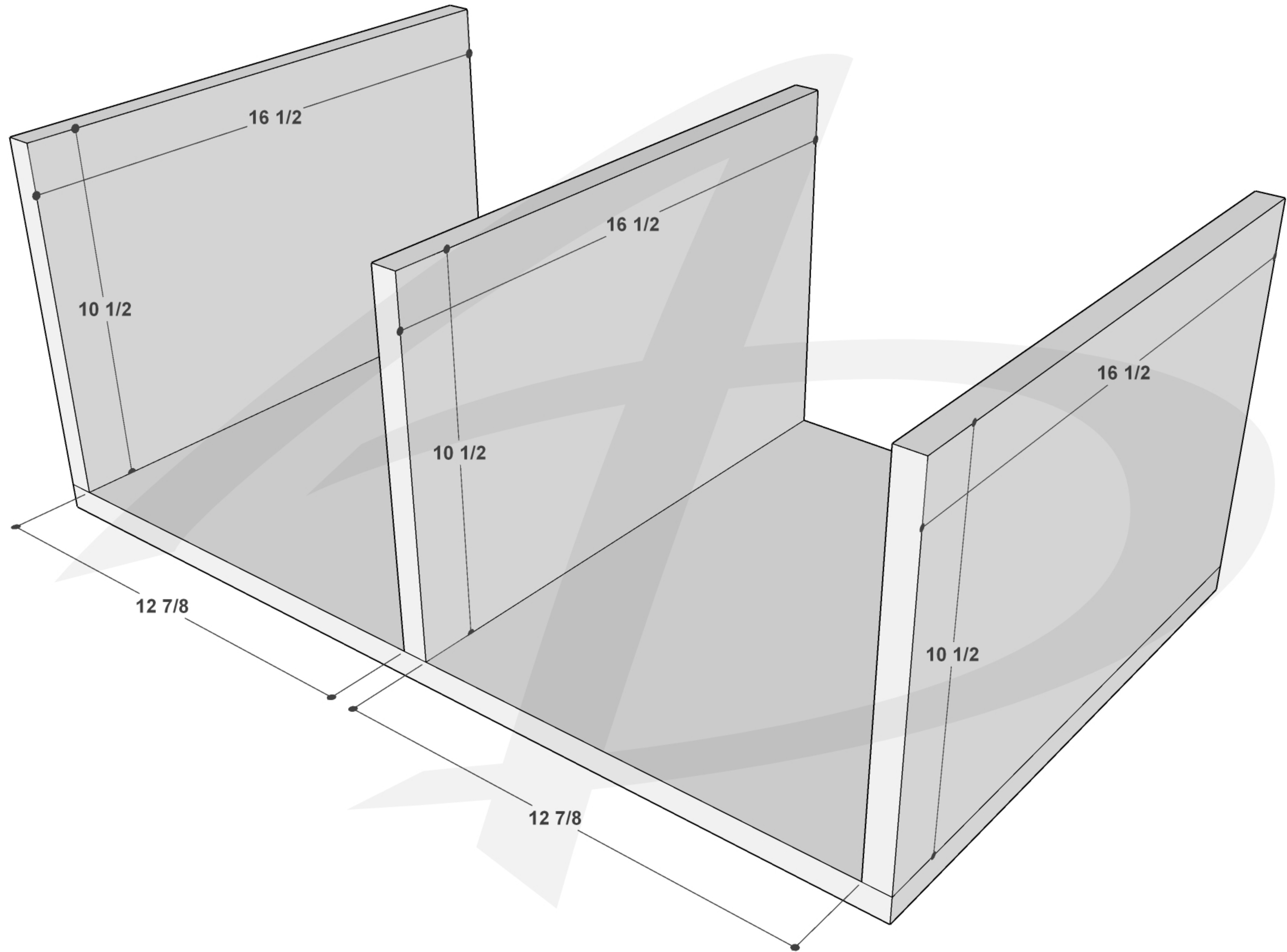

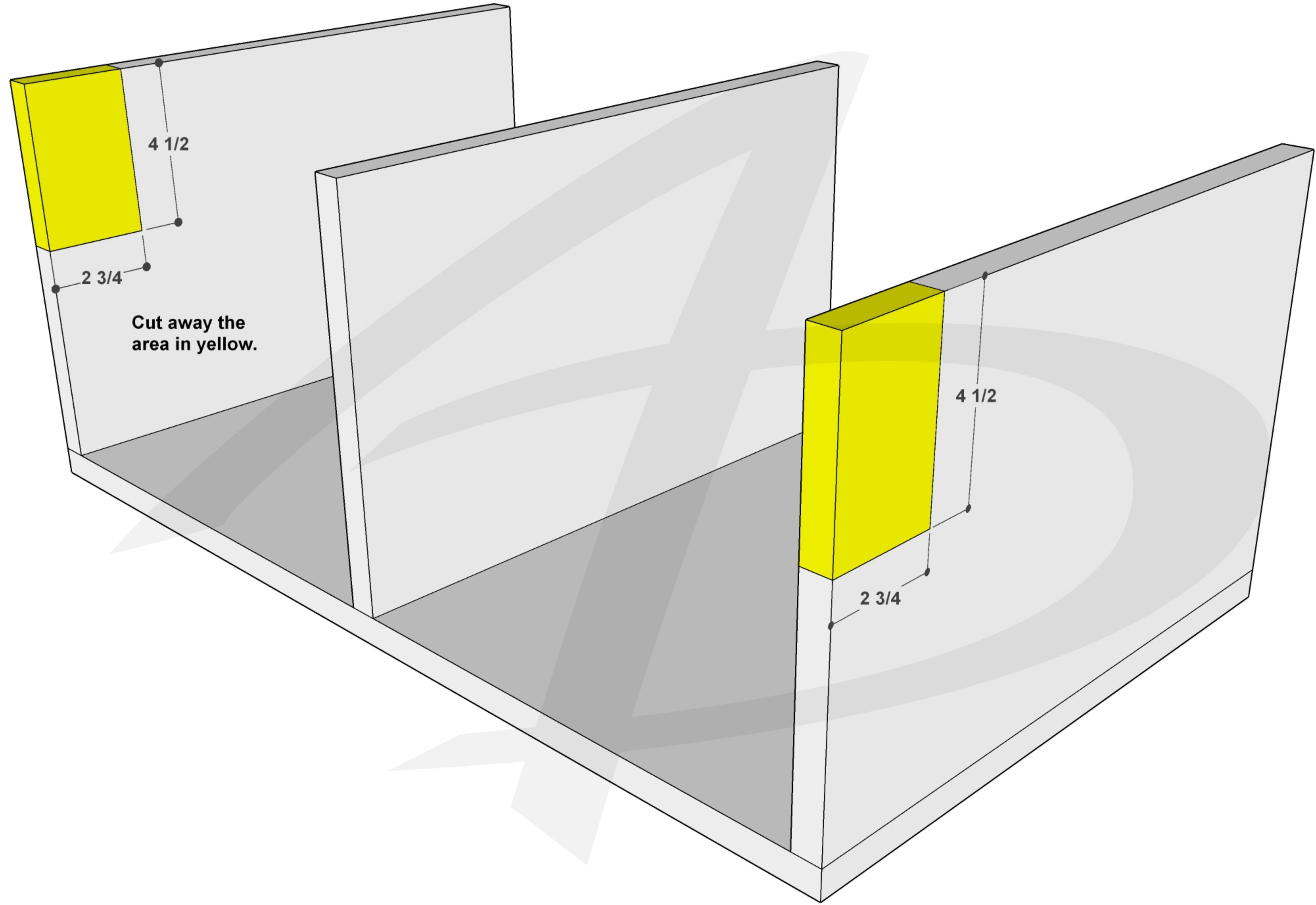

Cut away the area in yellow.

$4 \frac{1}{2}$

$2 \frac{3}{4}$

$4 \frac{1}{2}$

$2 \frac{3}{4}$

3/8"
round-over.

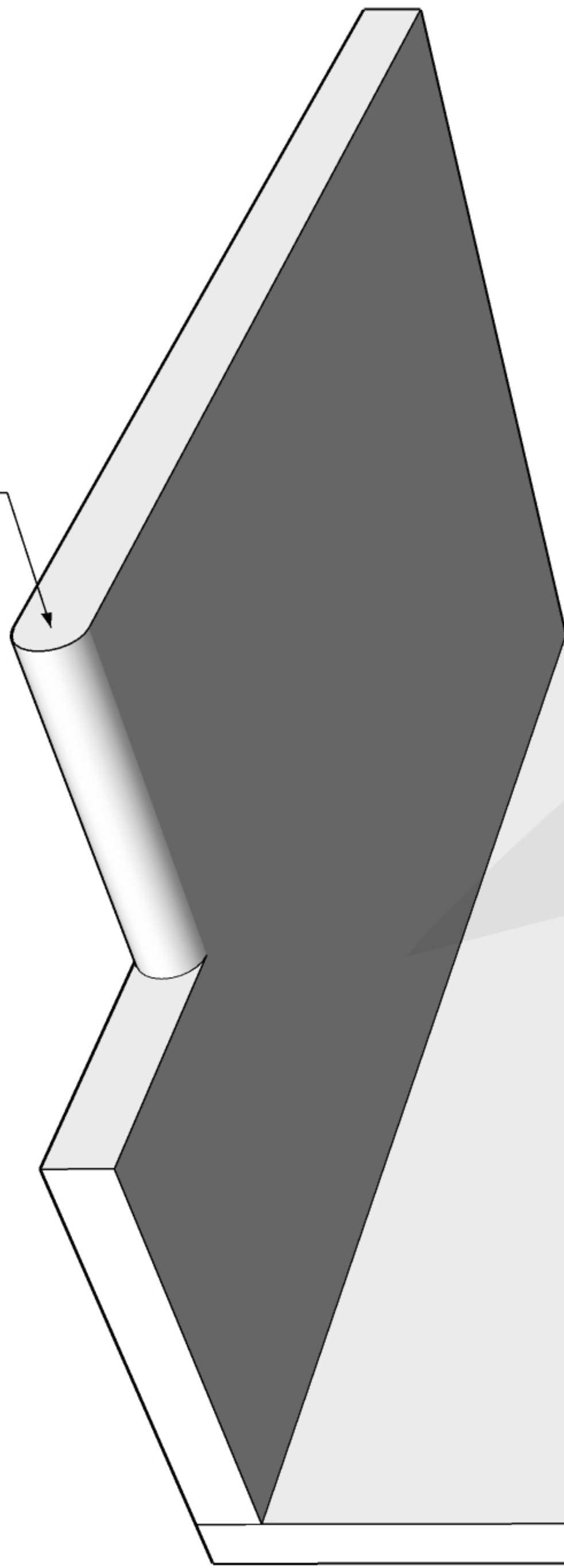

3/8"
round-over.

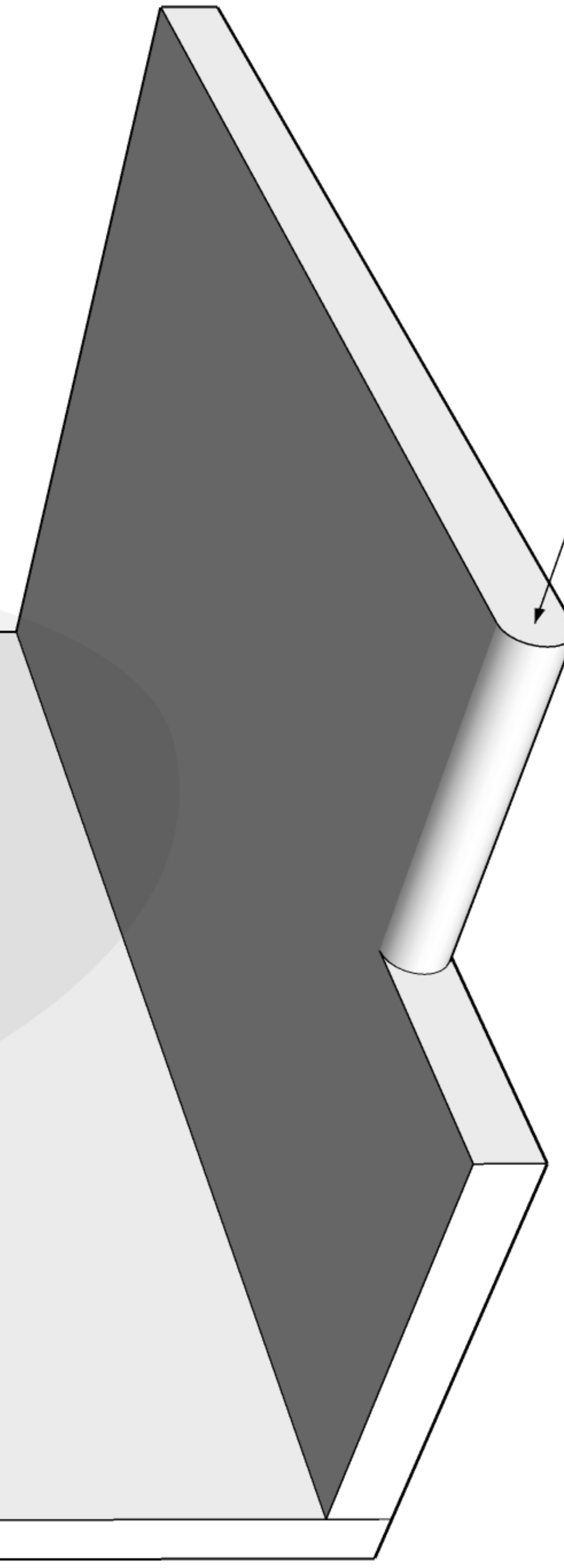

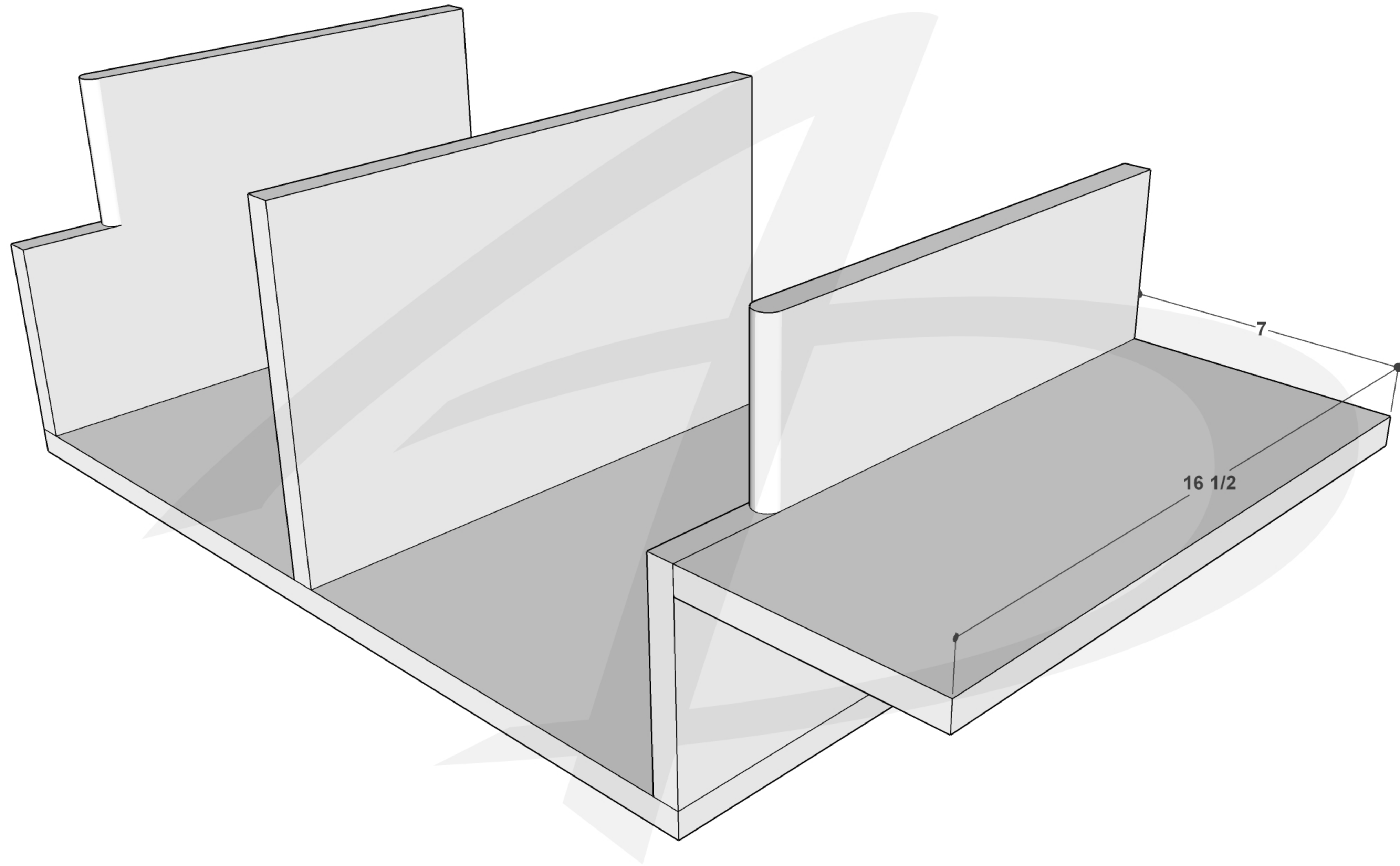

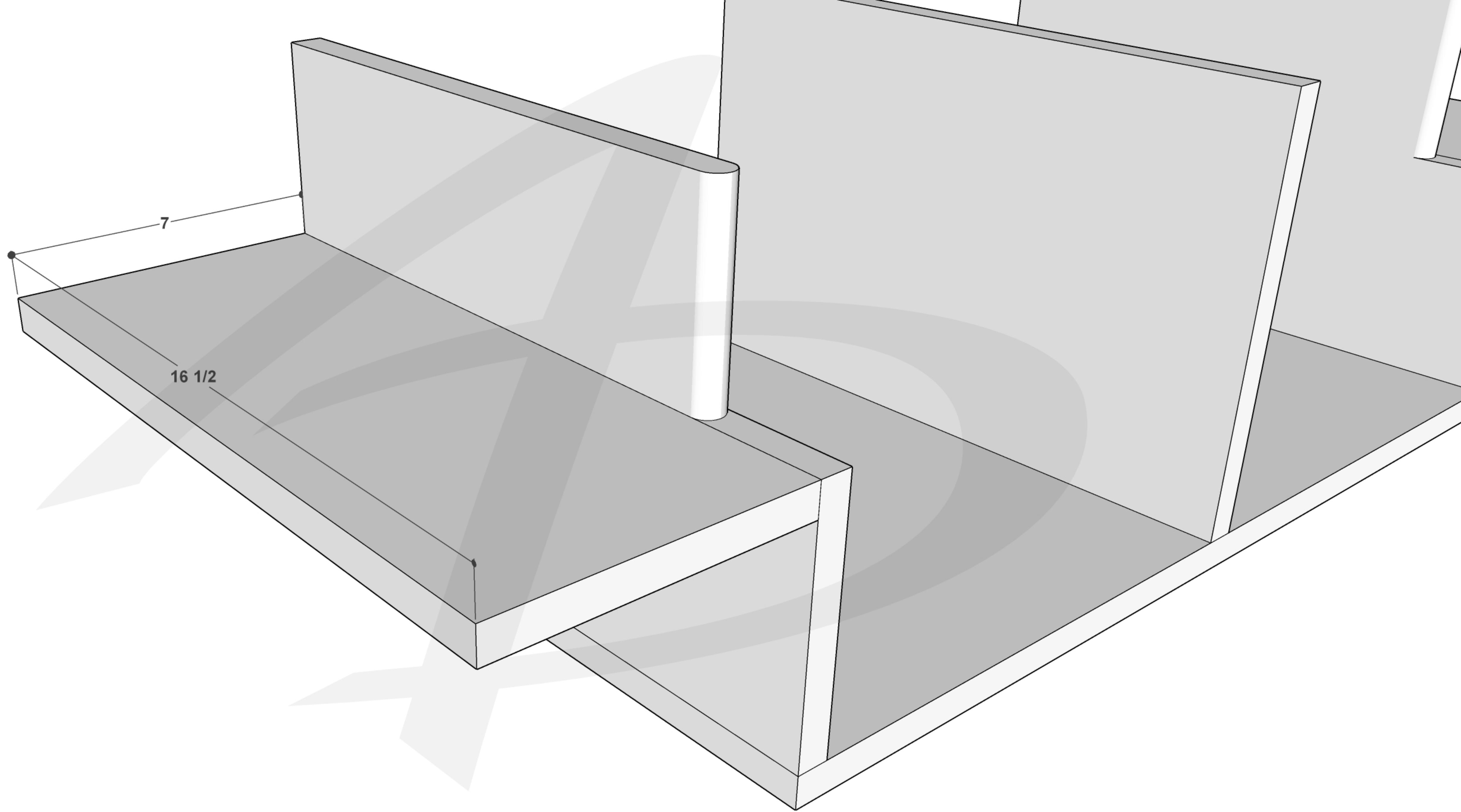

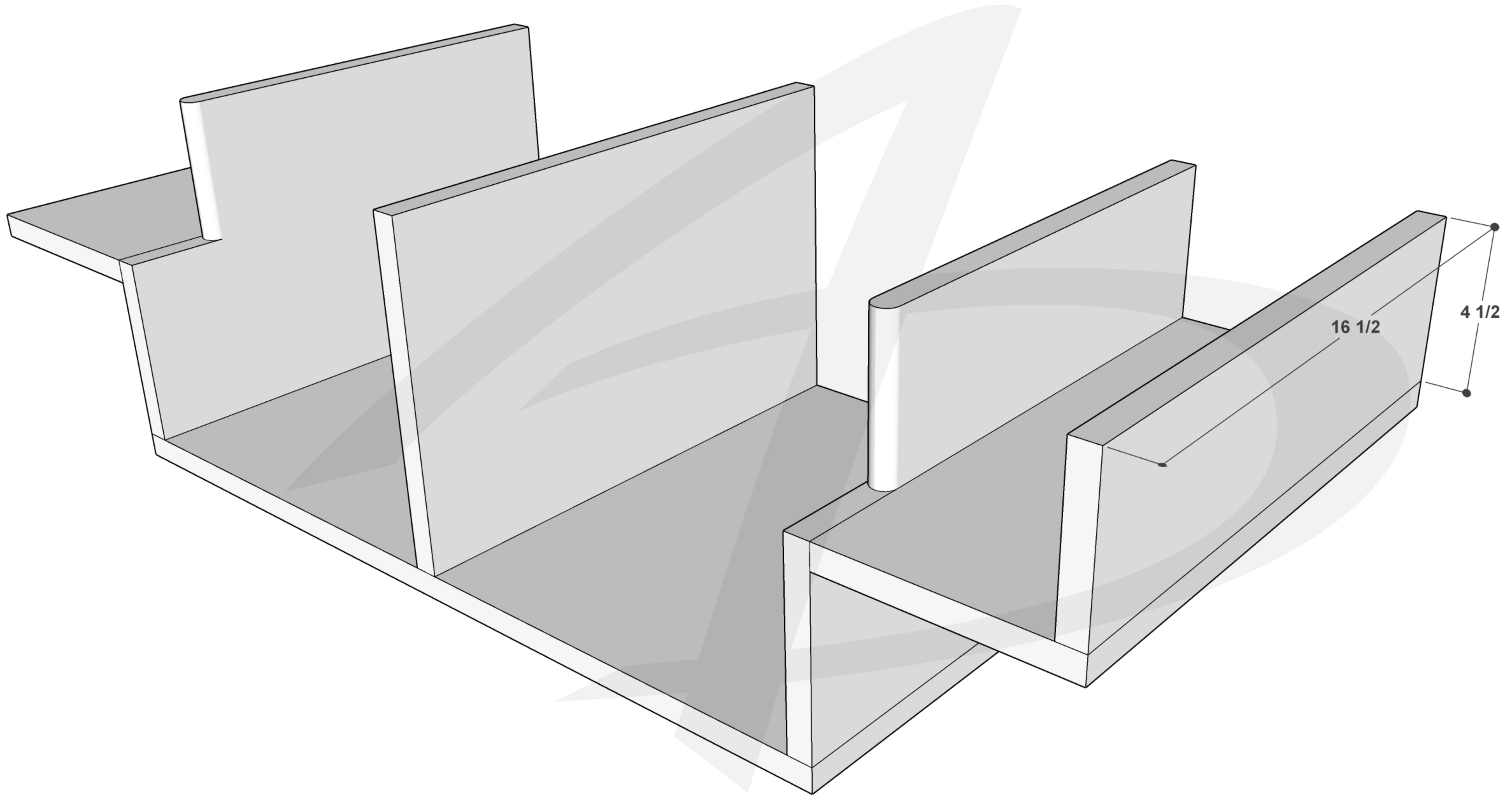

16 1/2

4 1/2

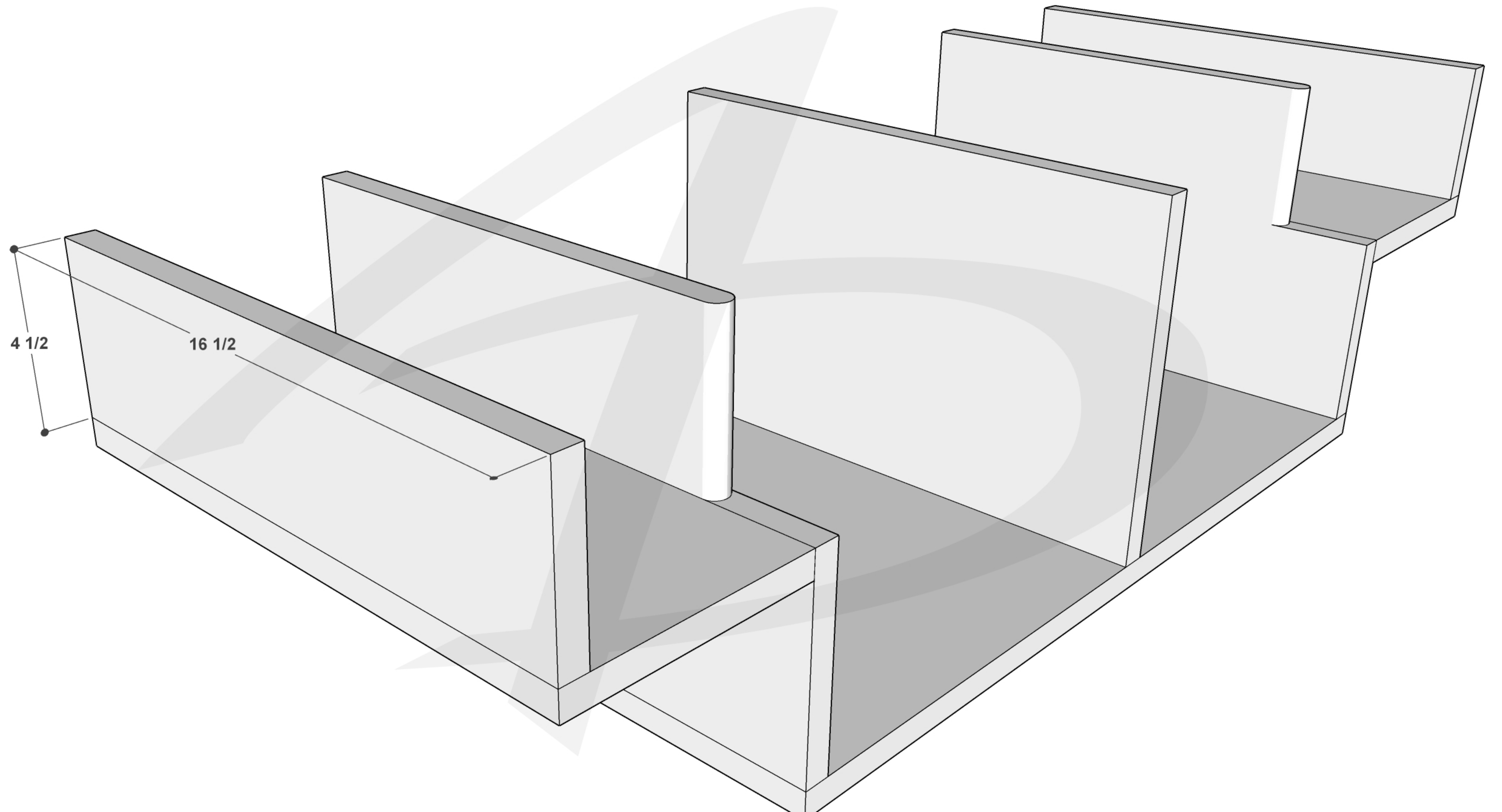

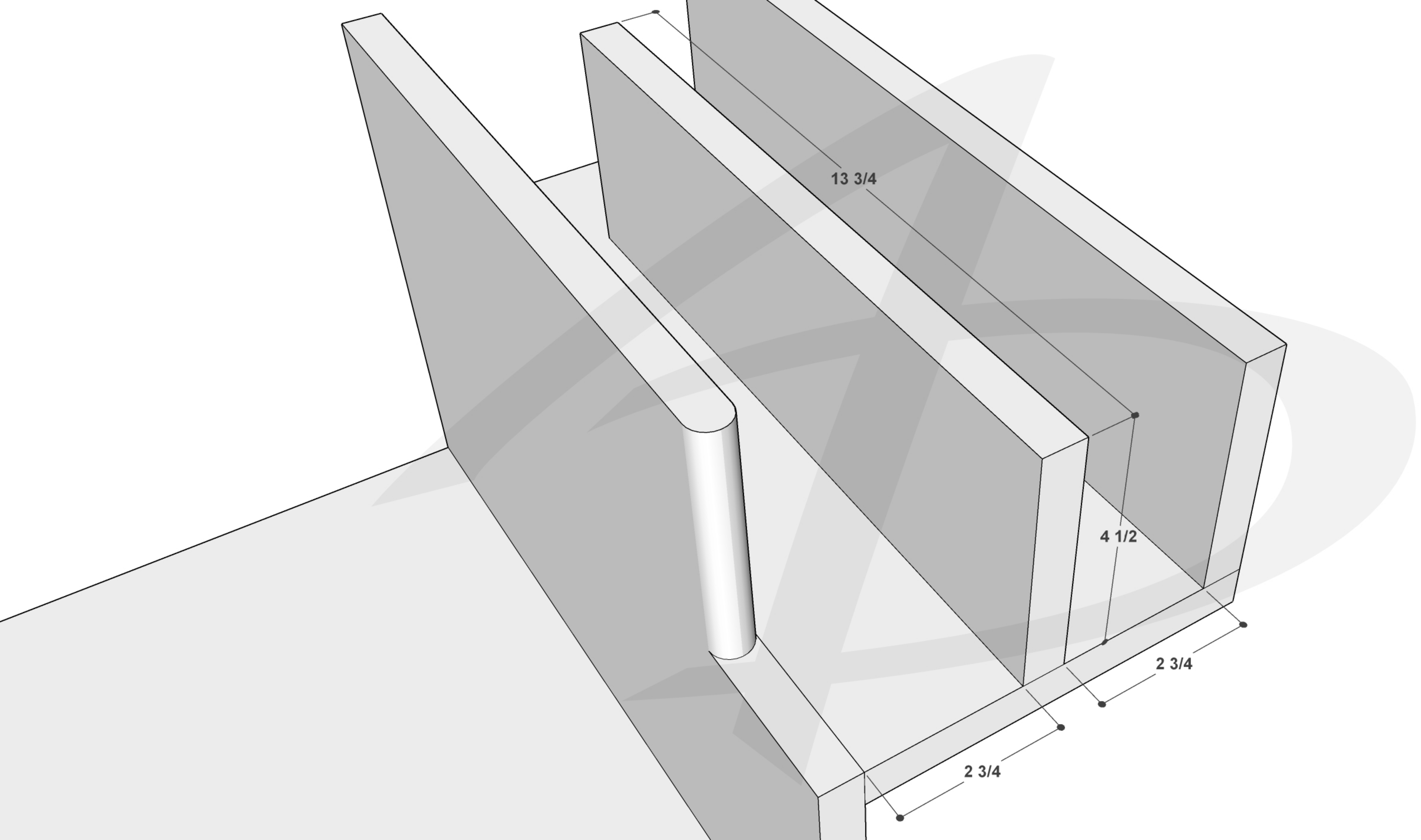

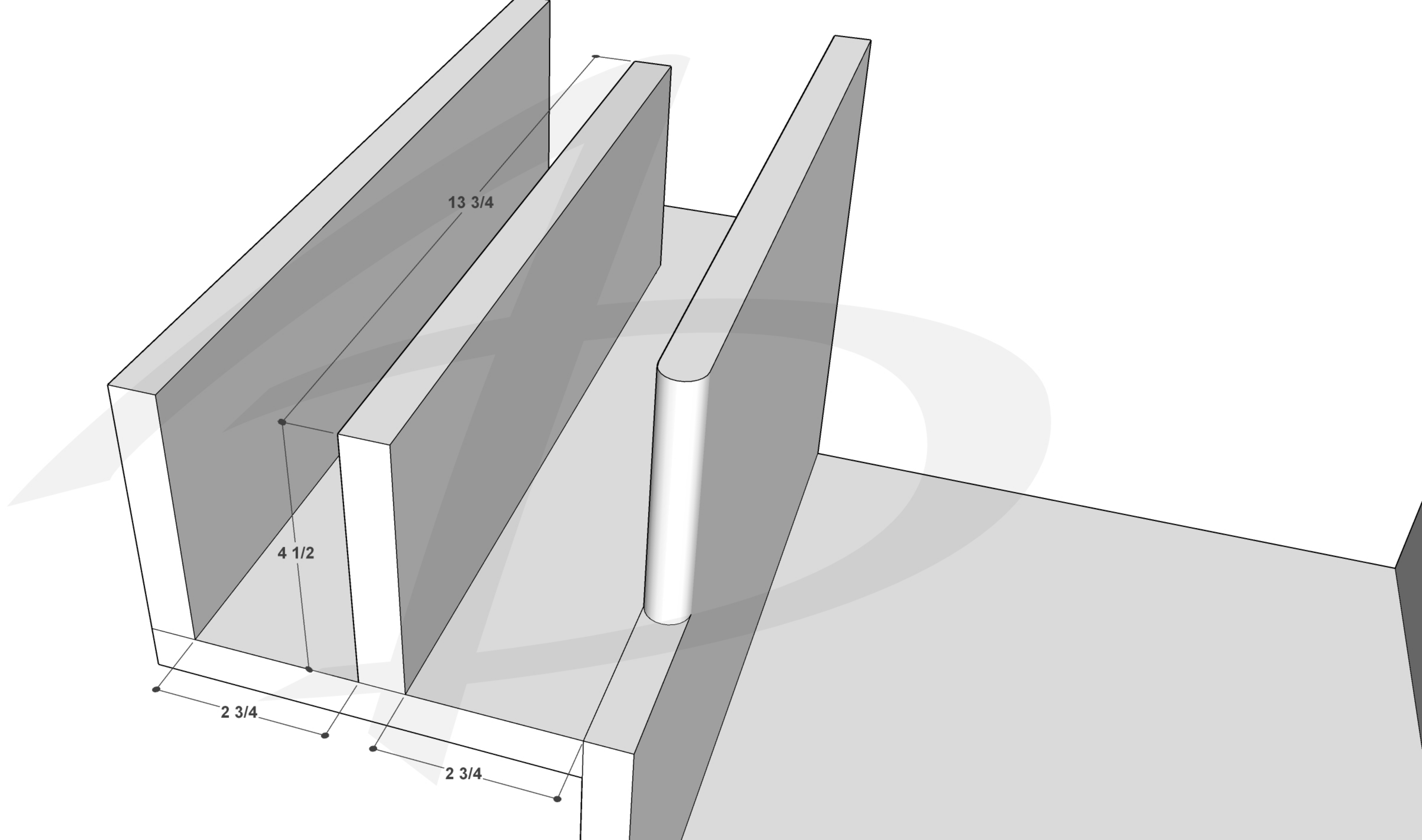

Apply 3/8" round-over.

Apply a 3/8" round-over.

