

Vehicle Information	
Year	2019
Make	Ford
Model	F150 Ext Cab

Enclosure Information	
Design Type	Bass-Reflex
Placement	In place of the rear seats.
Orientation	Position the enclosure with the subs directed upward.



AUDIO DYNAMICS

Special Notes

Amplifier Information	
Continuous Power Handling	4,000 W
Subsonic Filter Setting	20 Hz
Low Pass Filter Setting	28 Hz

Subwoofer Information	
Make	Audio Dynamics
Model	AD6018 D1
Quantity	2

Performance Information	
SQ	<input checked="" type="checkbox"/> Within the Vehicle
<input checked="" type="checkbox"/> SQL	Outside the Vehicle
SPL	Metering Position

Metering Information		
Headrest	Peak Frequency	Hz
Dash / Windshield		
Foot Well		

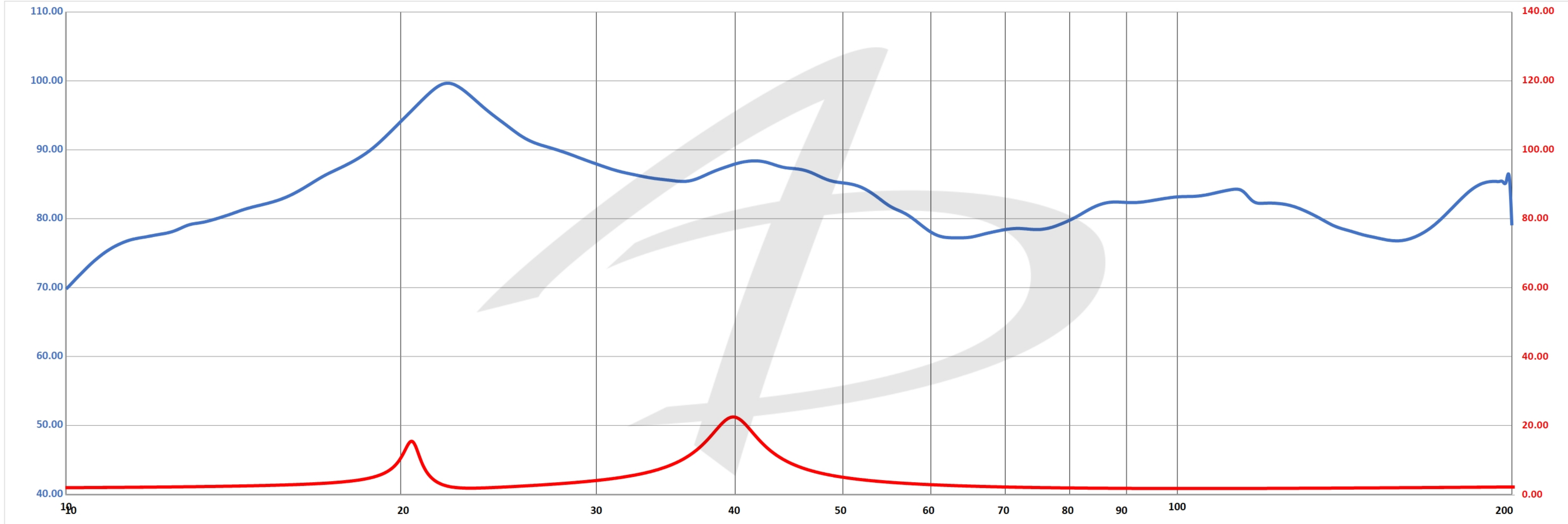

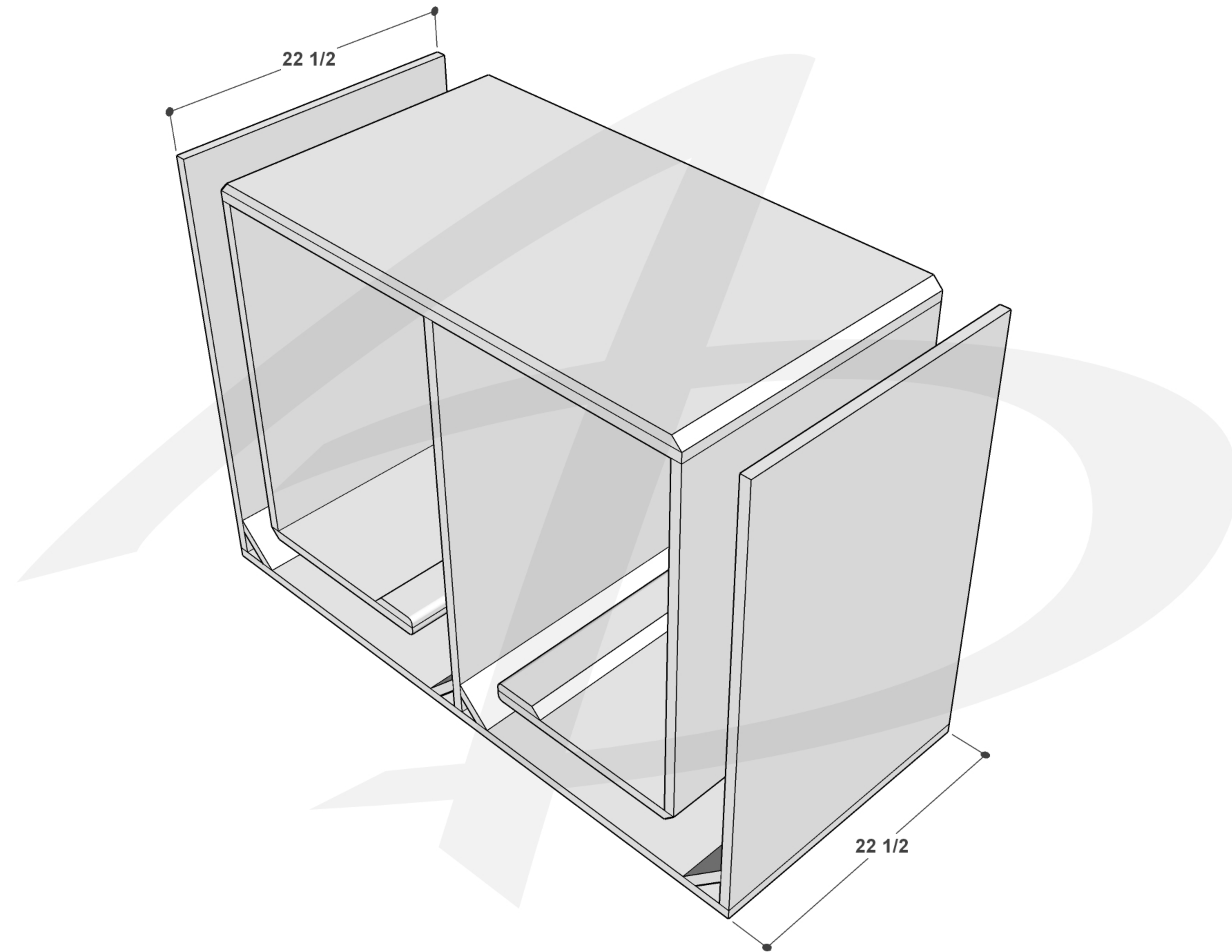

22 1/2

22 1/2

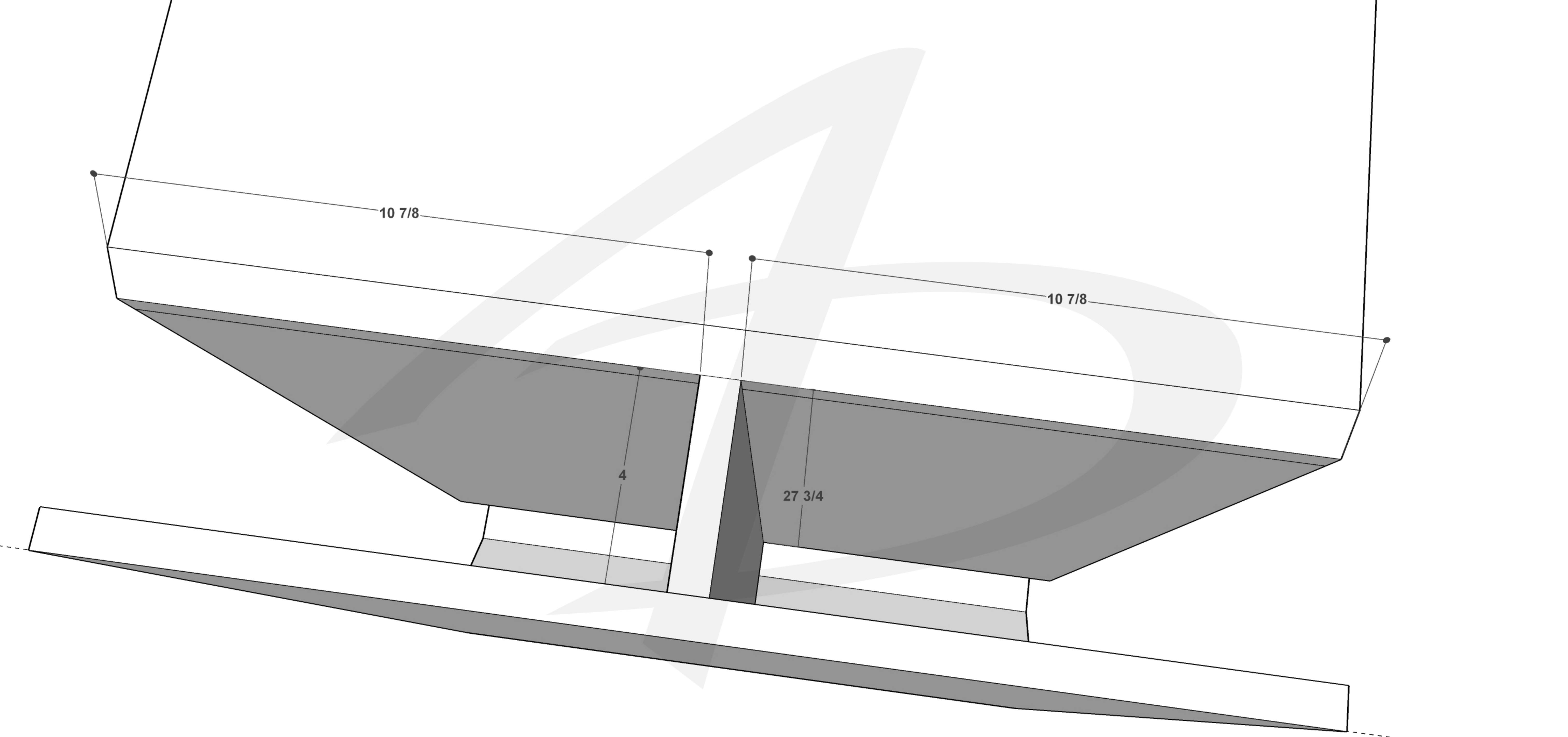

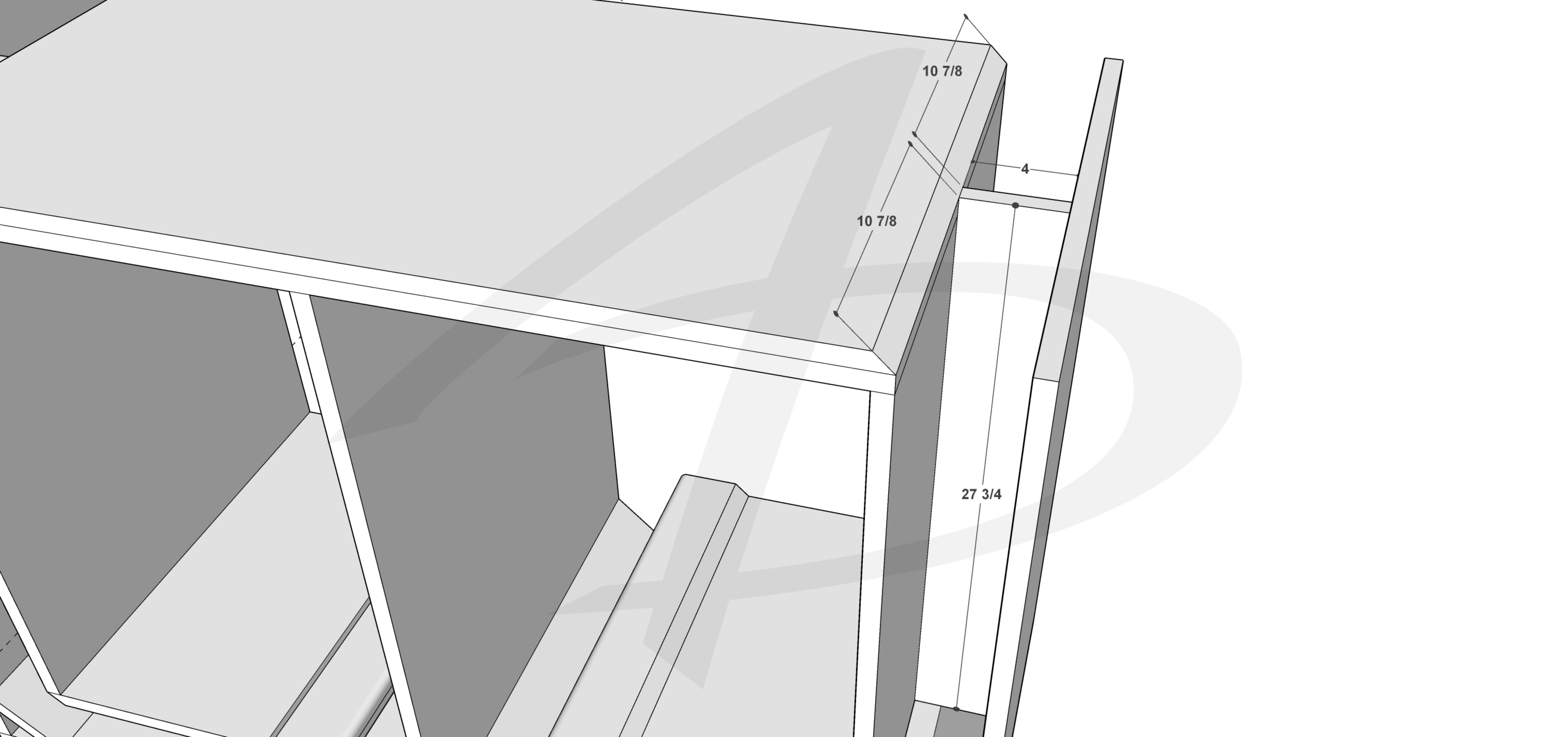

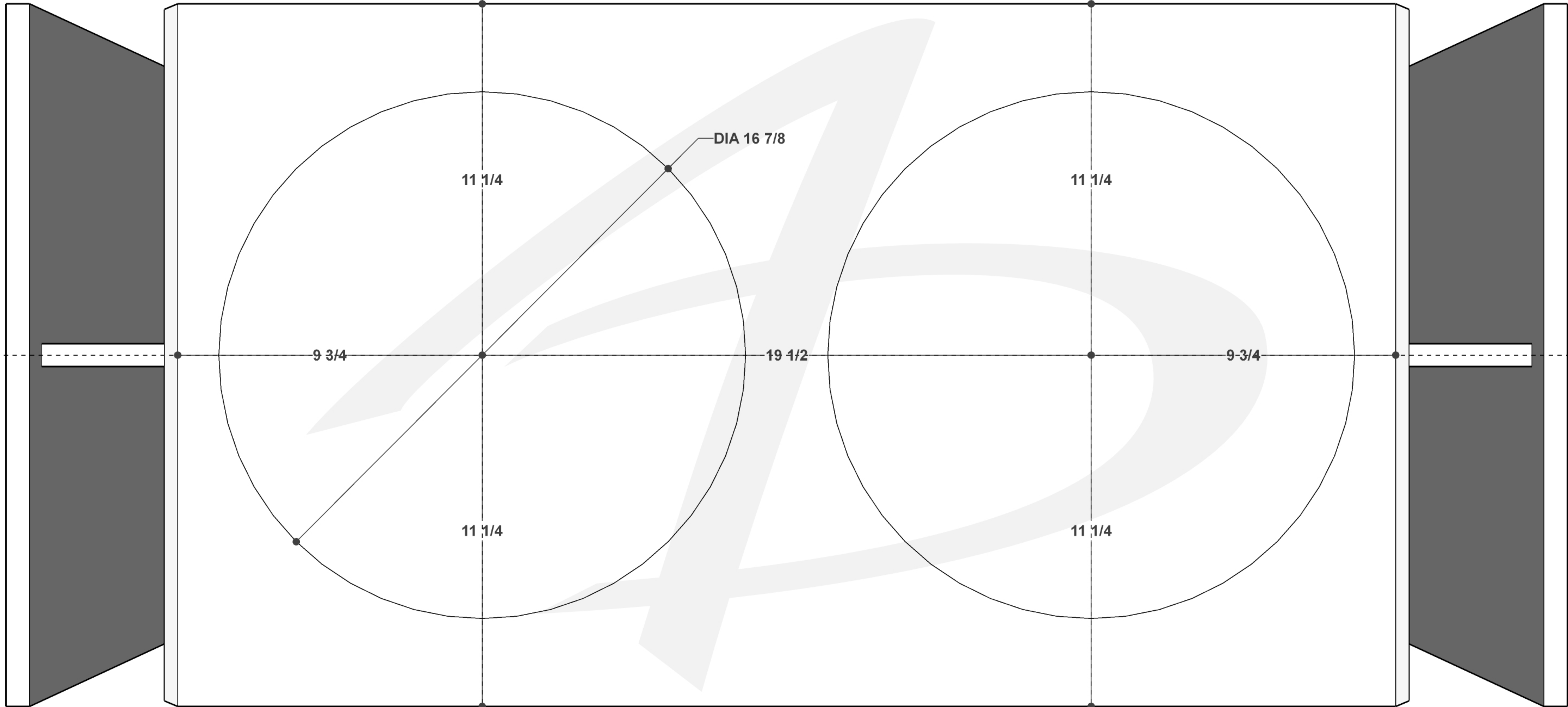

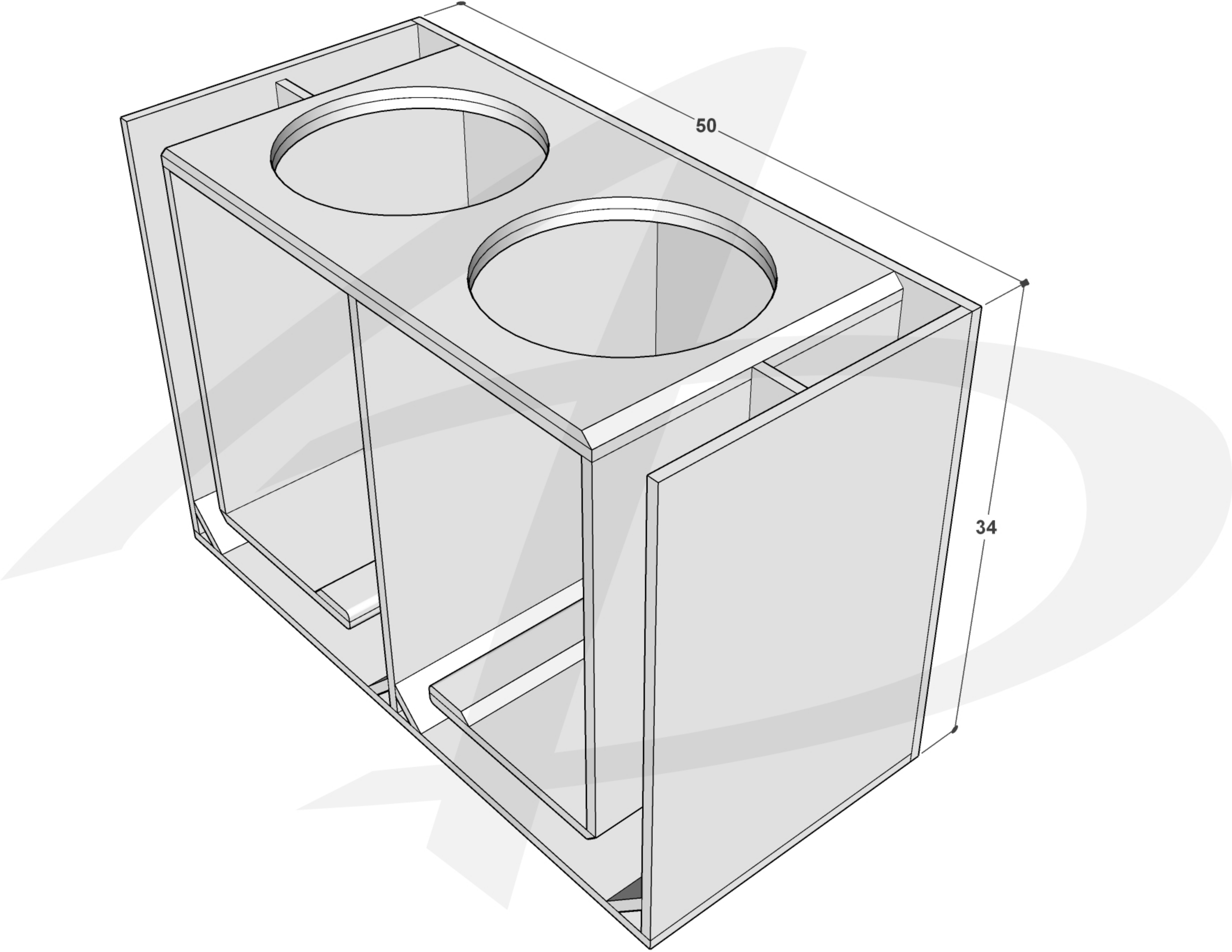

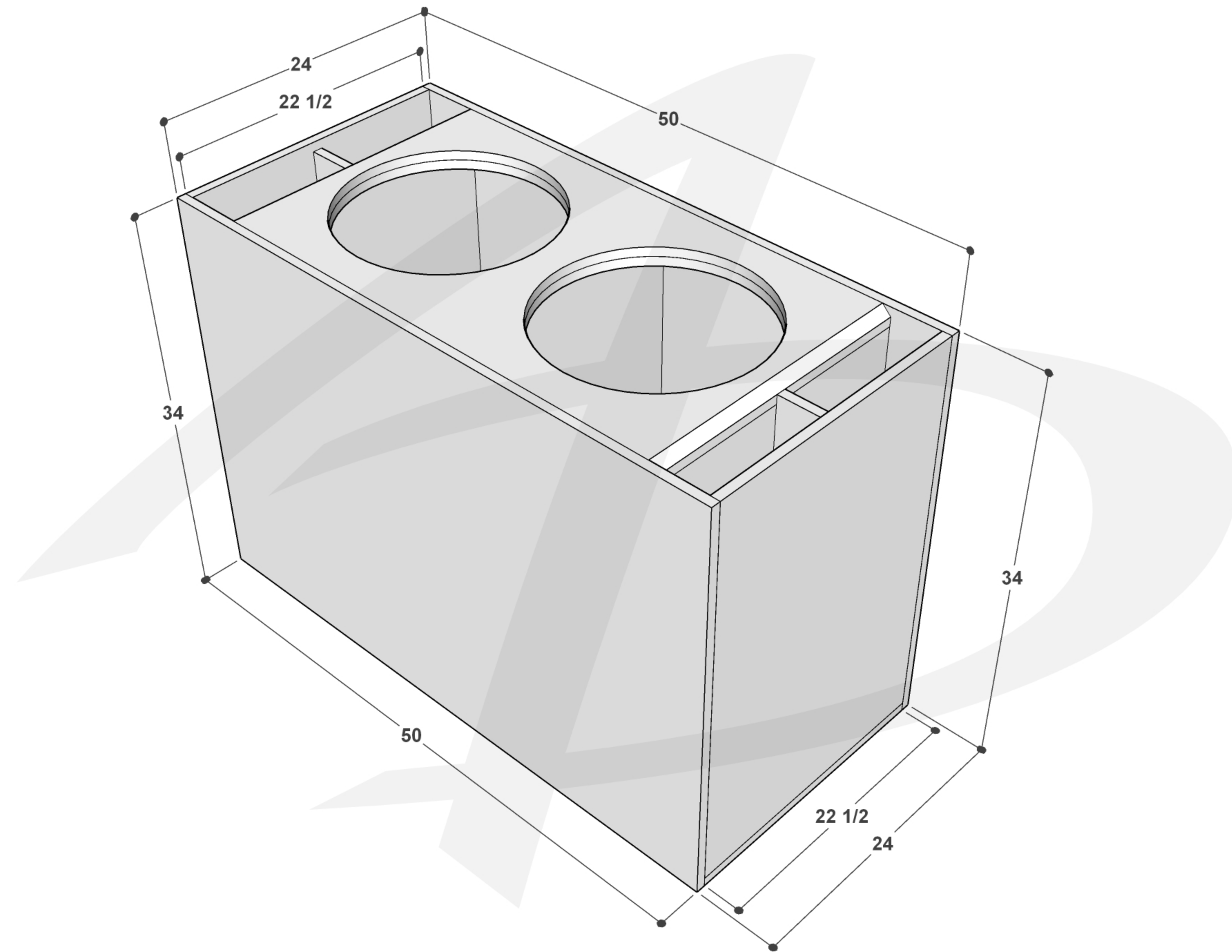

24
22 1/2

50

34

34

50

22 1/2

24

