



**AUDIO DYNAMICS**

Vehicle Information	
Year	Unspecified
Make	Unspecified
Model	Unspecified

Enclosure Information	
Design Type	Bass-Reflex
Placement	Trunk
Orientation	Position the enclosure with the subs directed rearward.

Special Notes

Amplifier Information	
Continuous Power Handling	1,200 W
Subsonic Filter Setting	32 Hz
Low Pass Filter Setting	70 Hz

Subwoofer Information	
Make	Audio Dynamics
Model	AD 3010 D2
Quantity	2

Performance Information	
SQ	<input checked="" type="checkbox"/> Within the Vehicle
<input checked="" type="checkbox"/> SQL	Outside the Vehicle
SPL	Metering Position

Metering Information		
Headrest	Peak Frequency	Hz
Dash / Windshield		
Foot Well		

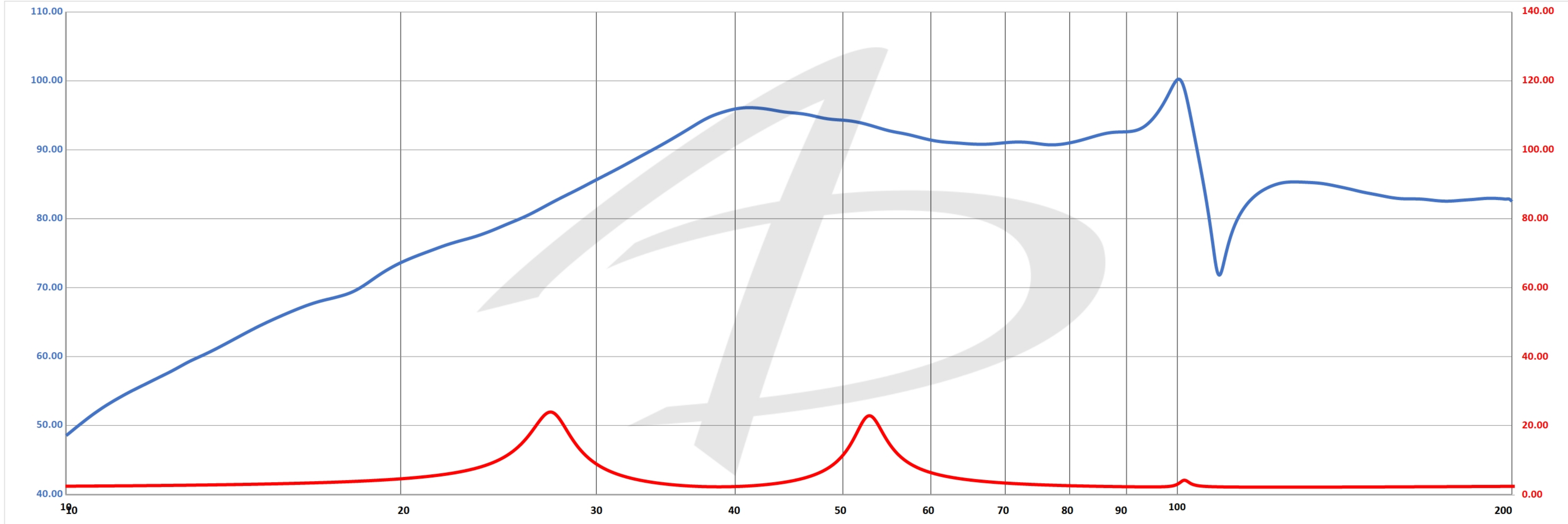

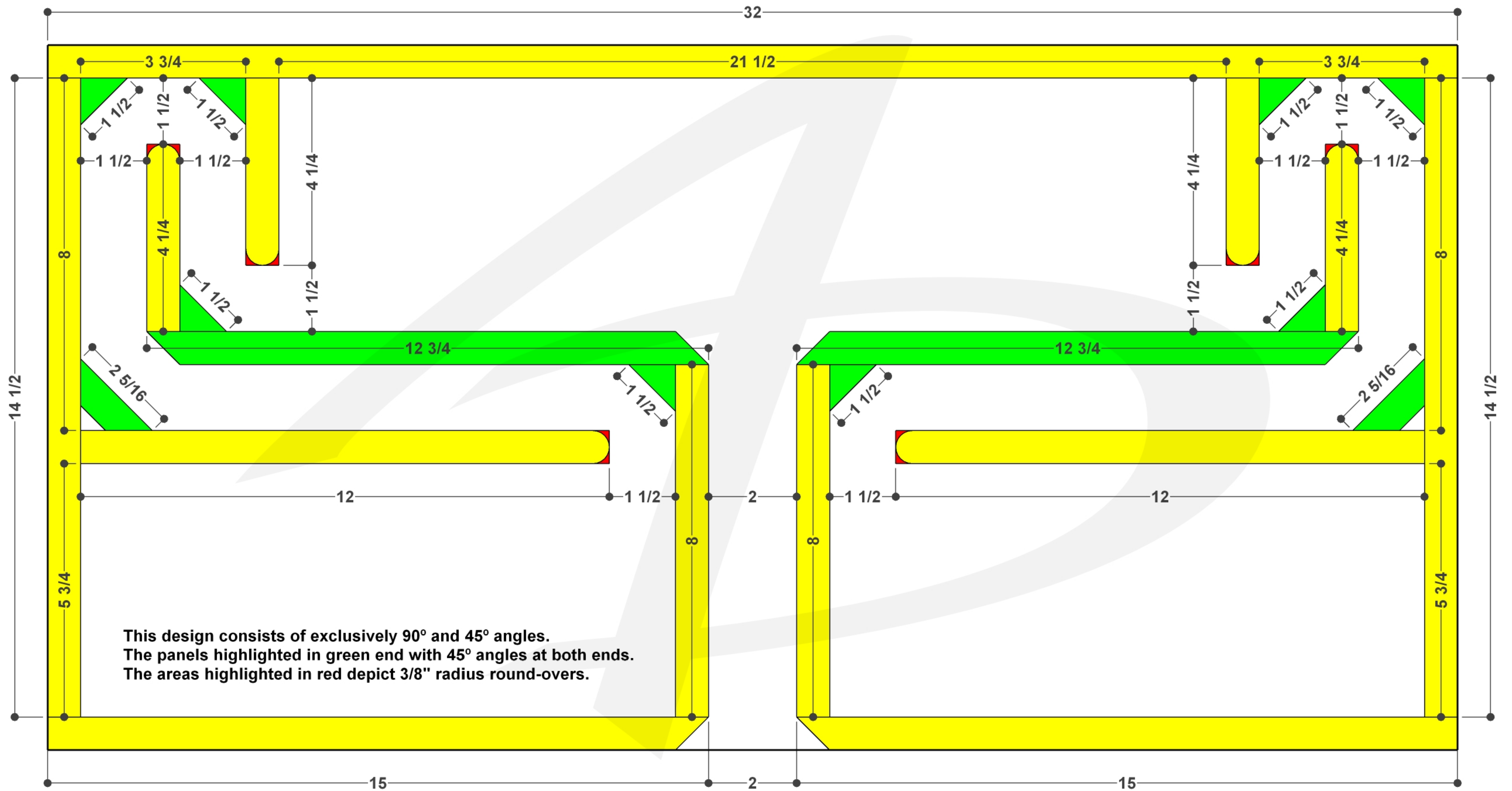

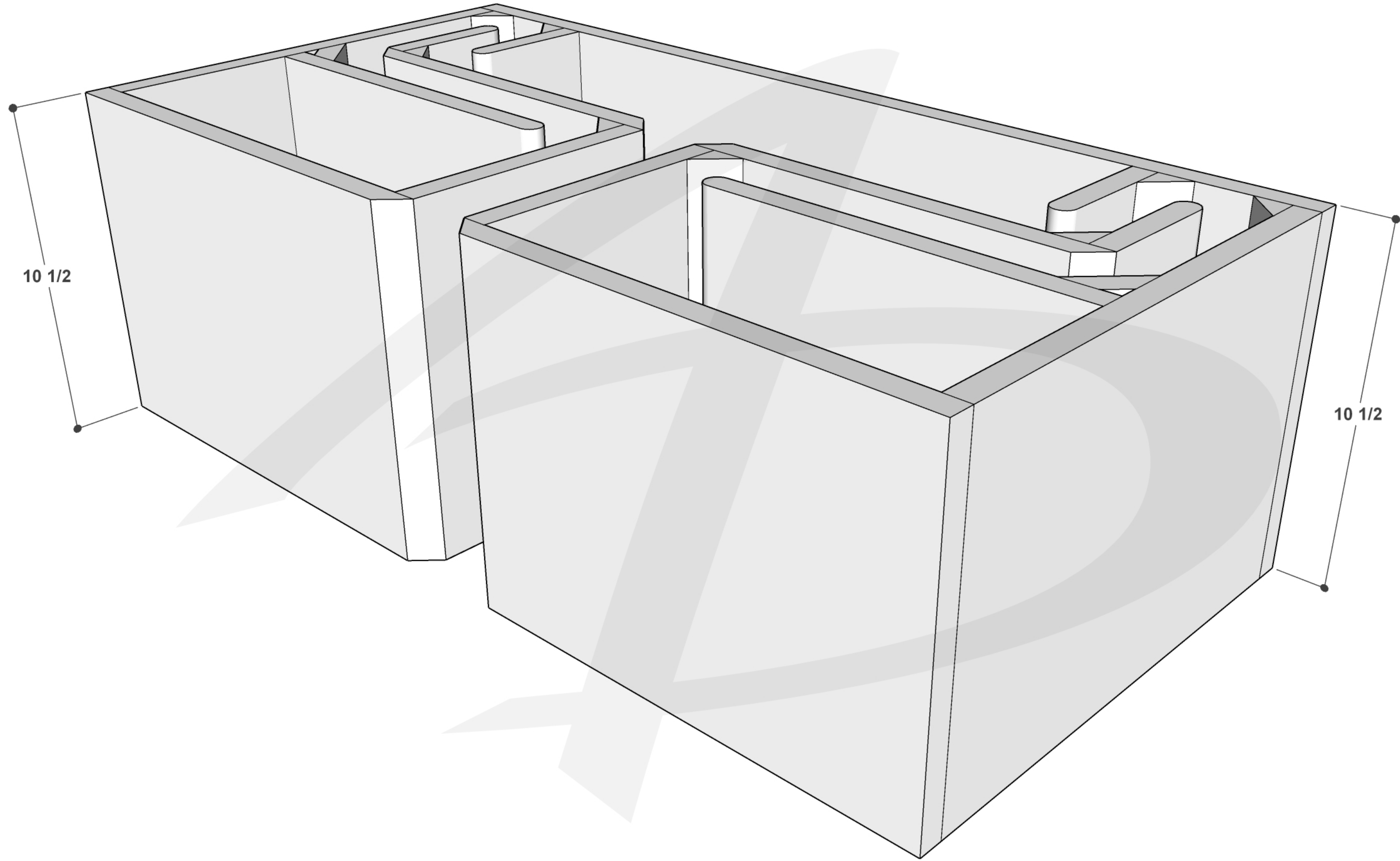

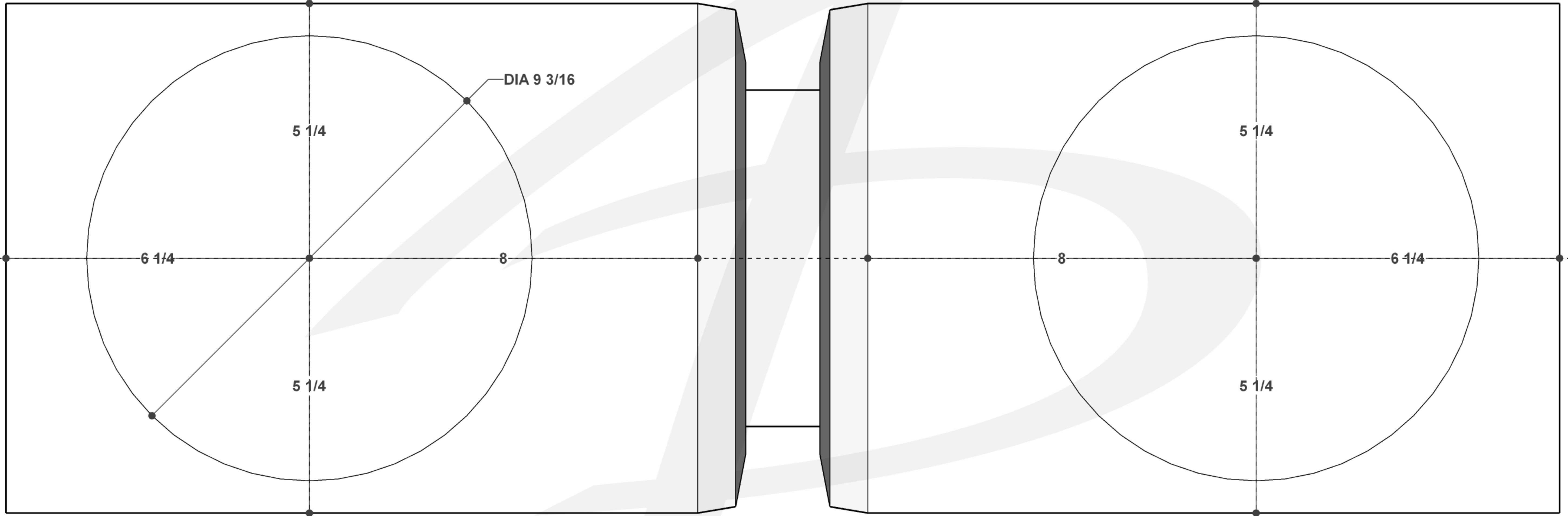

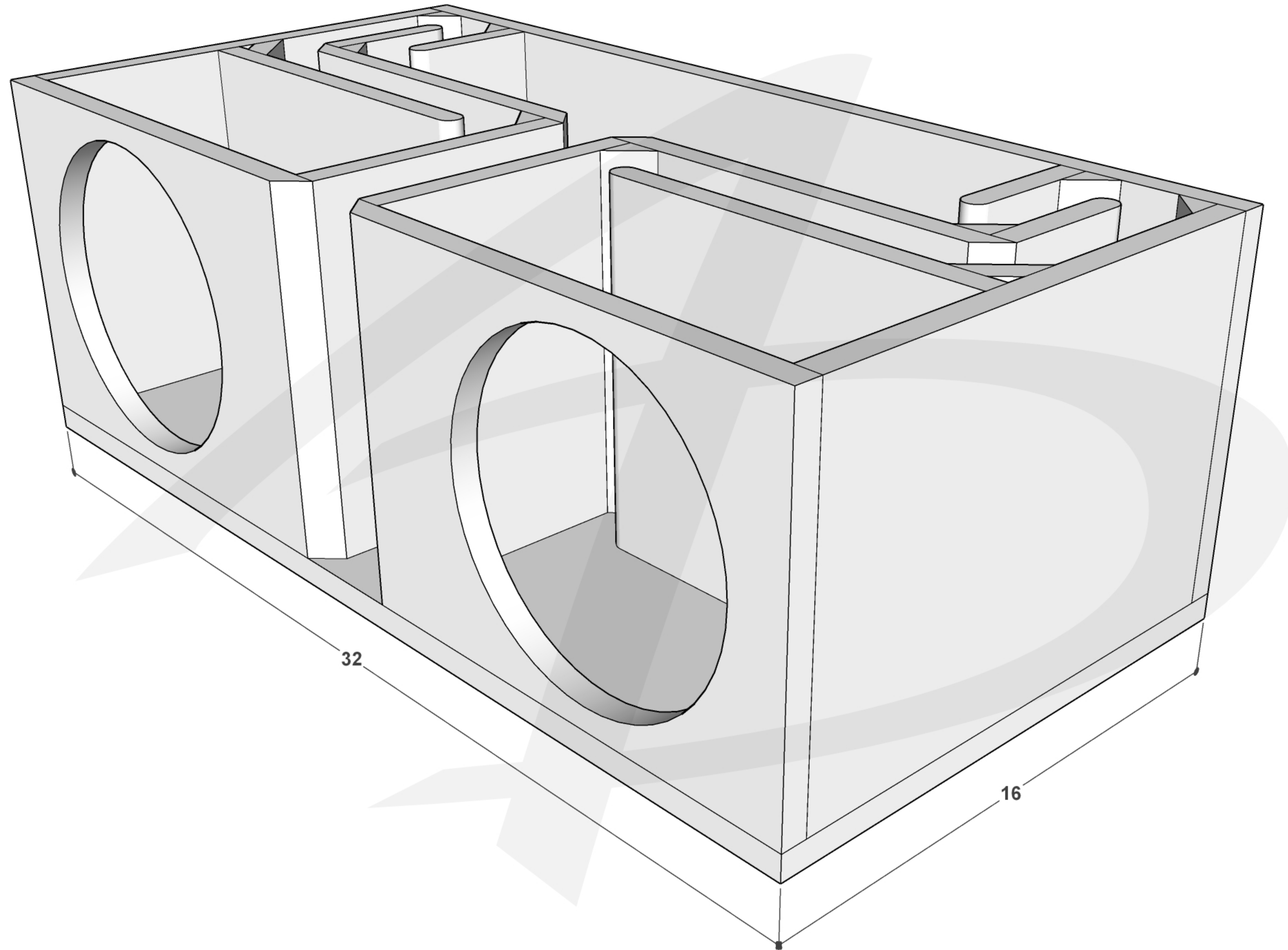

32

16

