

Vehicle Information	
Year	2003
Make	Chevy
Model	Silverado

Enclosure Information	
Design Type	Bass-Reflex
Placement	Behind the seats.
Orientation	Position the enclosure with the subs directed forward, vent directed toward the passenger side.



AUDIO DYNAMICS

Special Notes

Amplifier Information	
Continuous Power Handling	1,600 W
Subsonic Filter Setting	24 Hz
Low Pass Filter Setting	60 Hz

Subwoofer Information	
Make	Audio Dynamics
Model	AD2206 D2
Quantity	4

Performance Information	
SQ	<input checked="" type="checkbox"/> Within the Vehicle
<input checked="" type="checkbox"/> SQL	Outside the Vehicle
SPL	Metering Position

Metering Information		
Headrest	Peak Frequency	Hz
Dash / Windshield		
Foot Well		

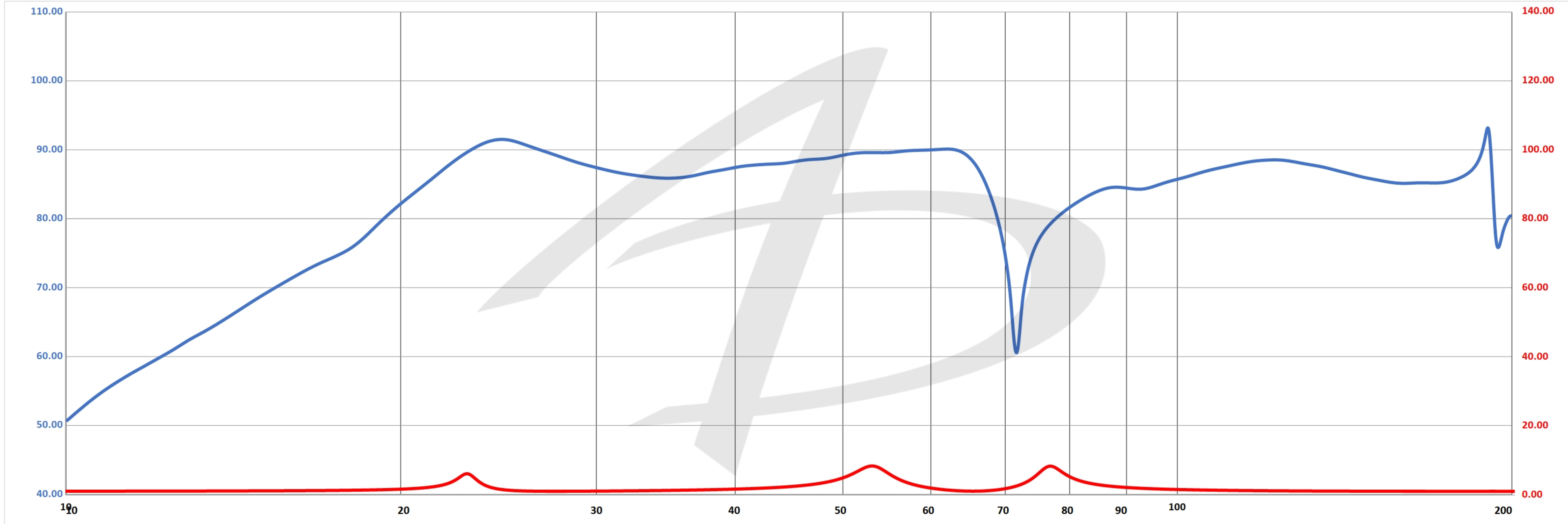

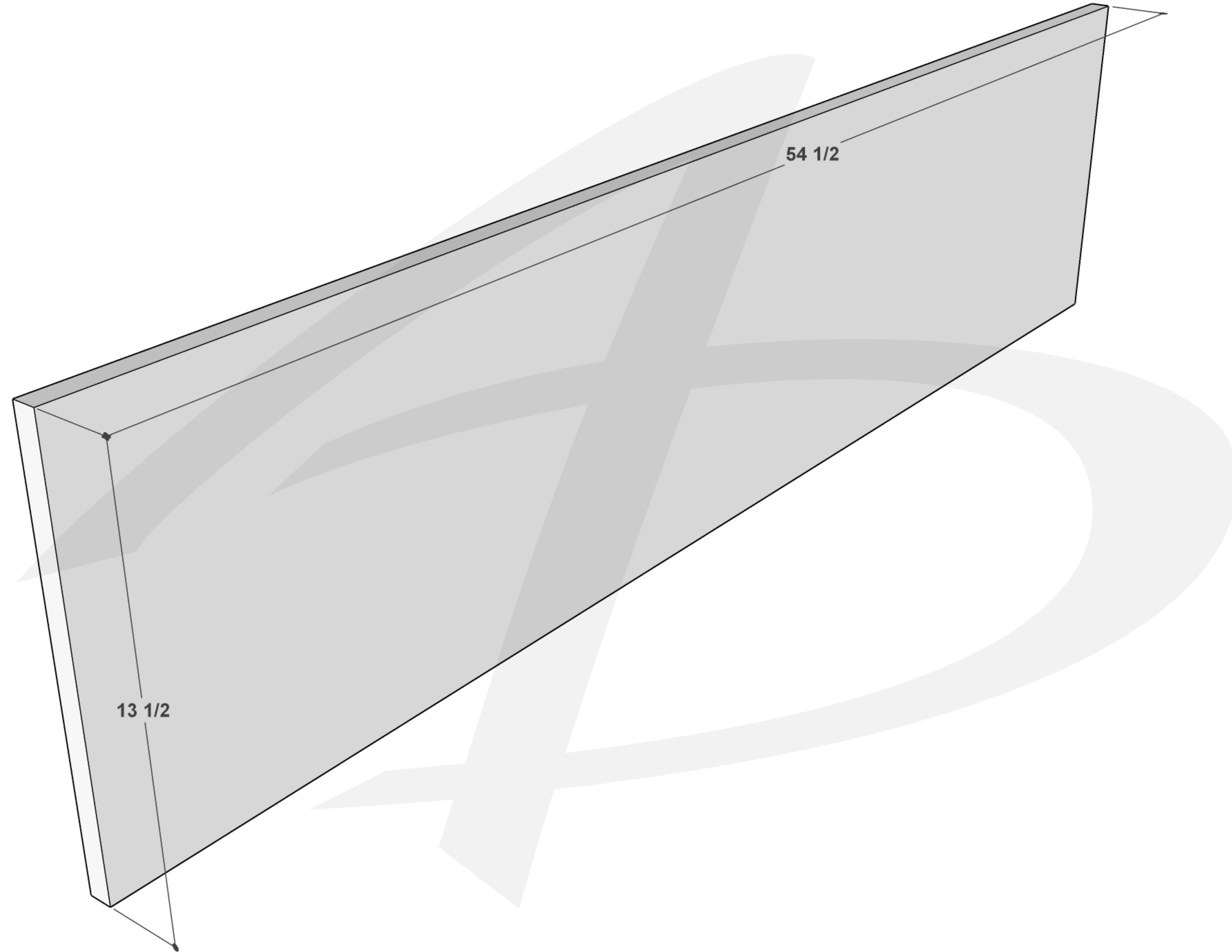

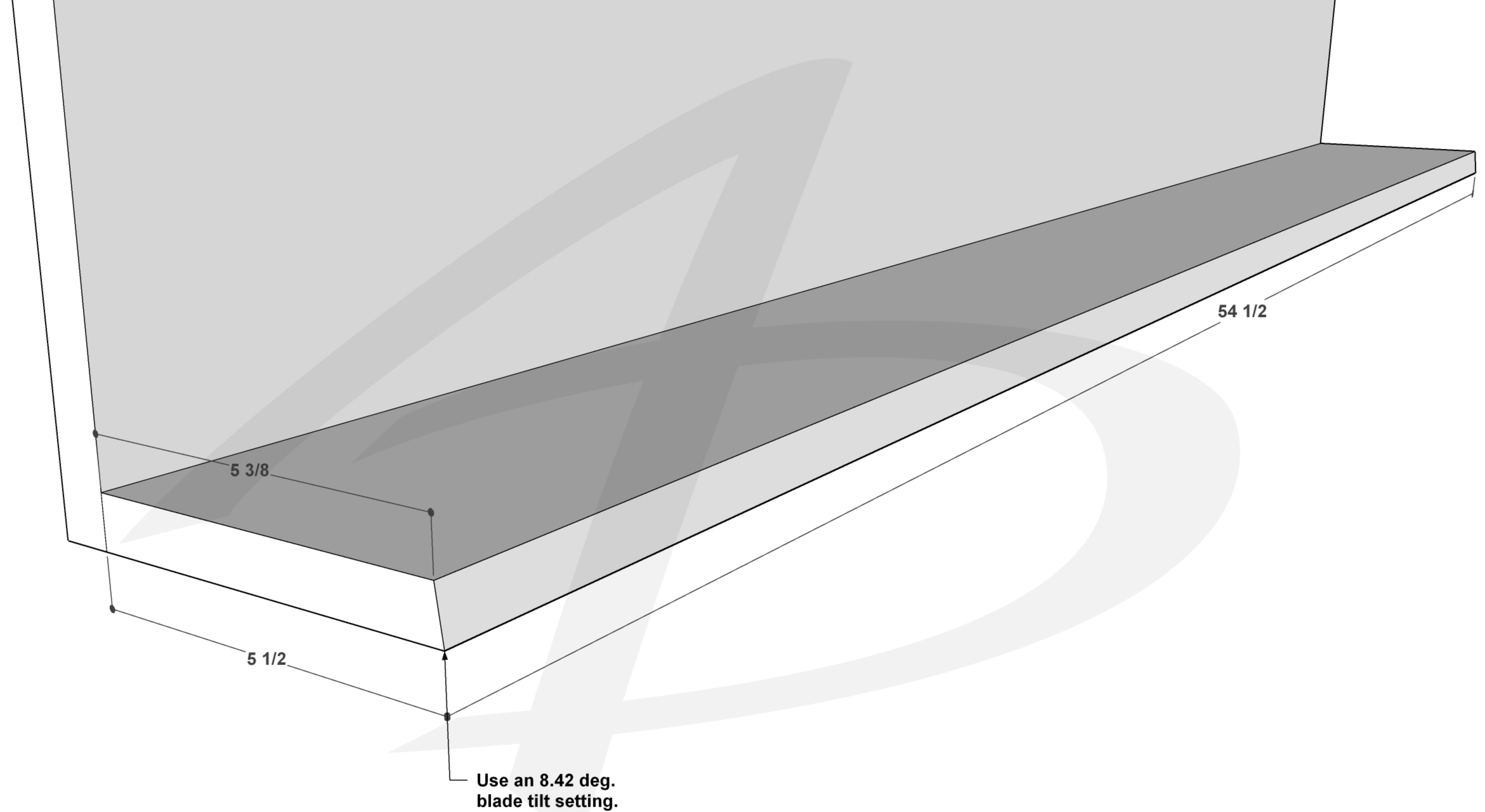

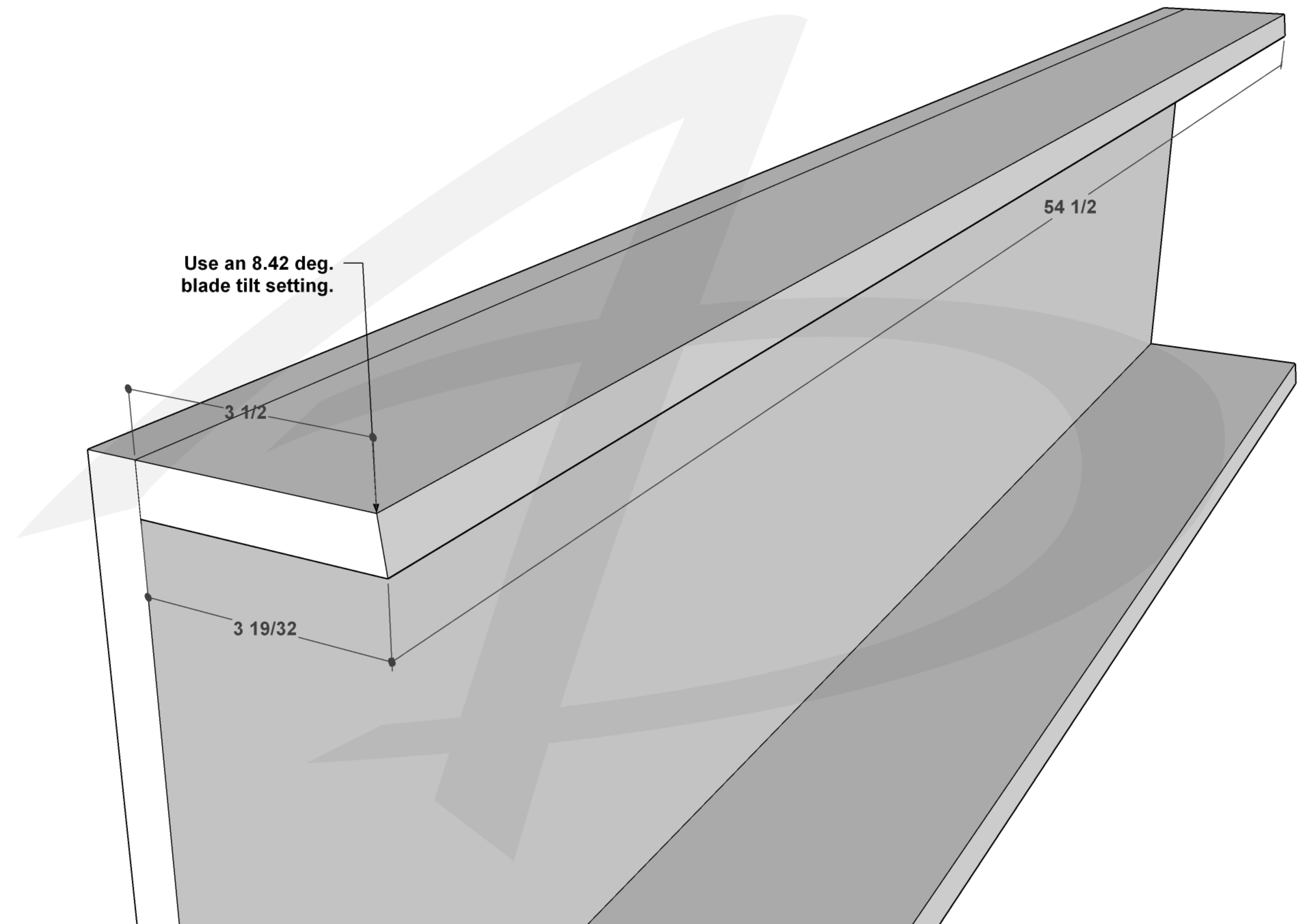

Use an 8.42 deg.
blade tilt setting.

$3 \frac{1}{2}$

$3 \frac{19}{32}$

$54 \frac{1}{2}$

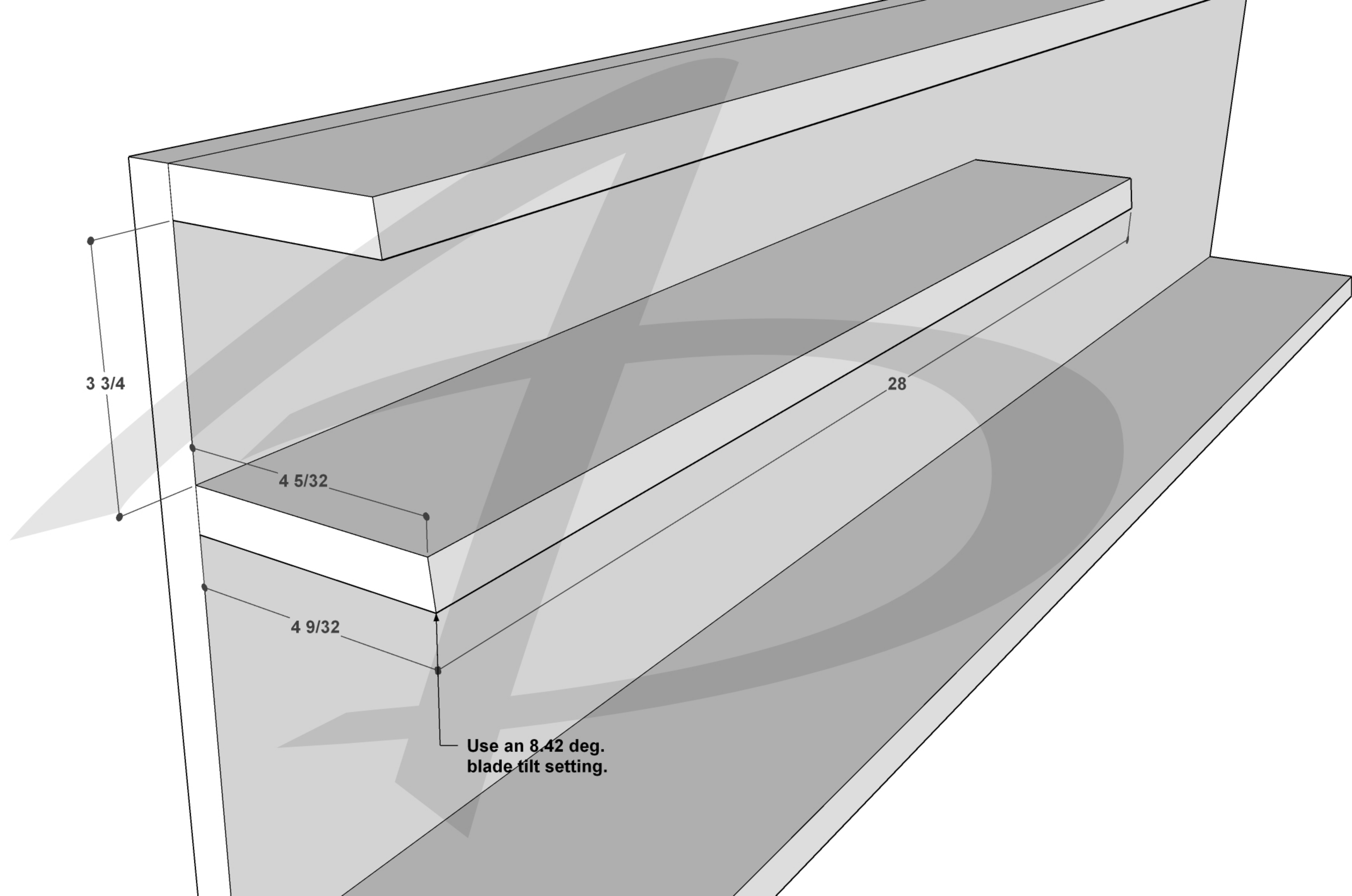

$3 \frac{3}{4}$

$4 \frac{5}{32}$

$4 \frac{9}{32}$

28

Use an 8.42 deg.
blade tilt setting.

