



AUDIO DYNAMICS

Vehicle Information	
Year	2012
Make	Supra
Model	Launch 24 SSV

Enclosure Information	
Design Type	Bass-Reflex
Placement	Unspecified
Orientation	Unspecified

Special Notes

Amplifier Information	
Continuous Power Handling	1,200 W
Subsonic Filter Setting	28 Hz
Low Pass Filter Setting	70 Hz

Subwoofer Information	
Make	Audio Dynamics
Model	AD3010 D4
Quantity	2

Performance Information	
SQ	<input checked="" type="checkbox"/> Within the Vehicle
<input checked="" type="checkbox"/> SQL	Outside the Vehicle
SPL	Metering Position

Metering Information		
Headrest	Peak Frequency	Hz
Dash / Windshield		
Foot Well		

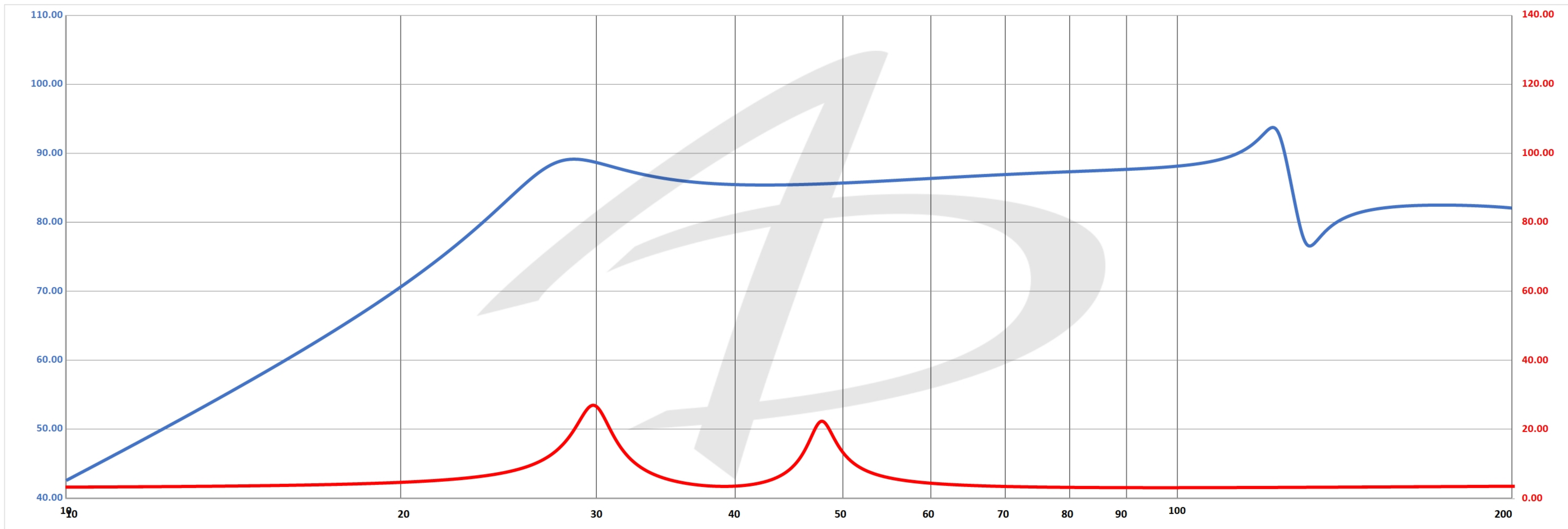

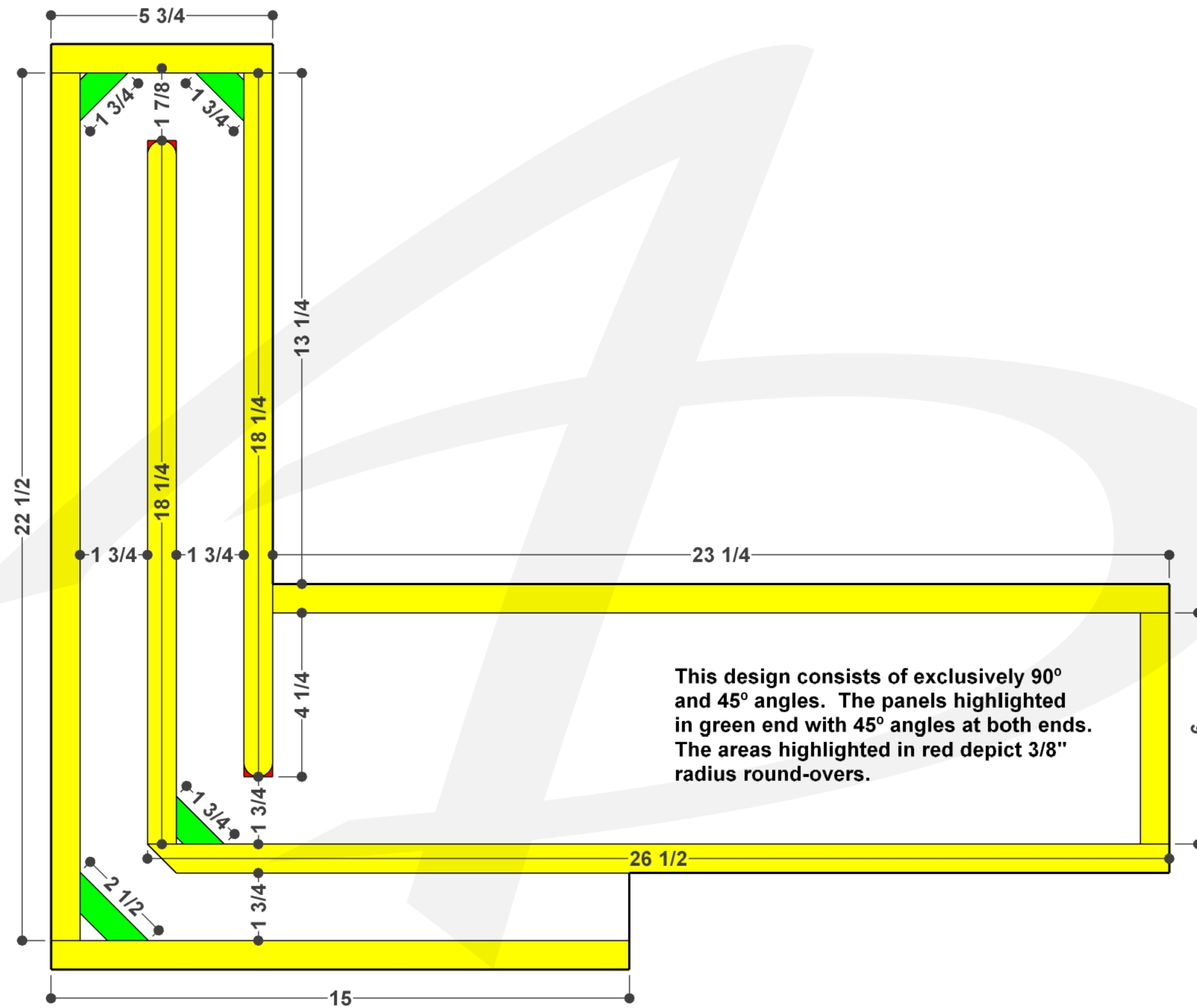

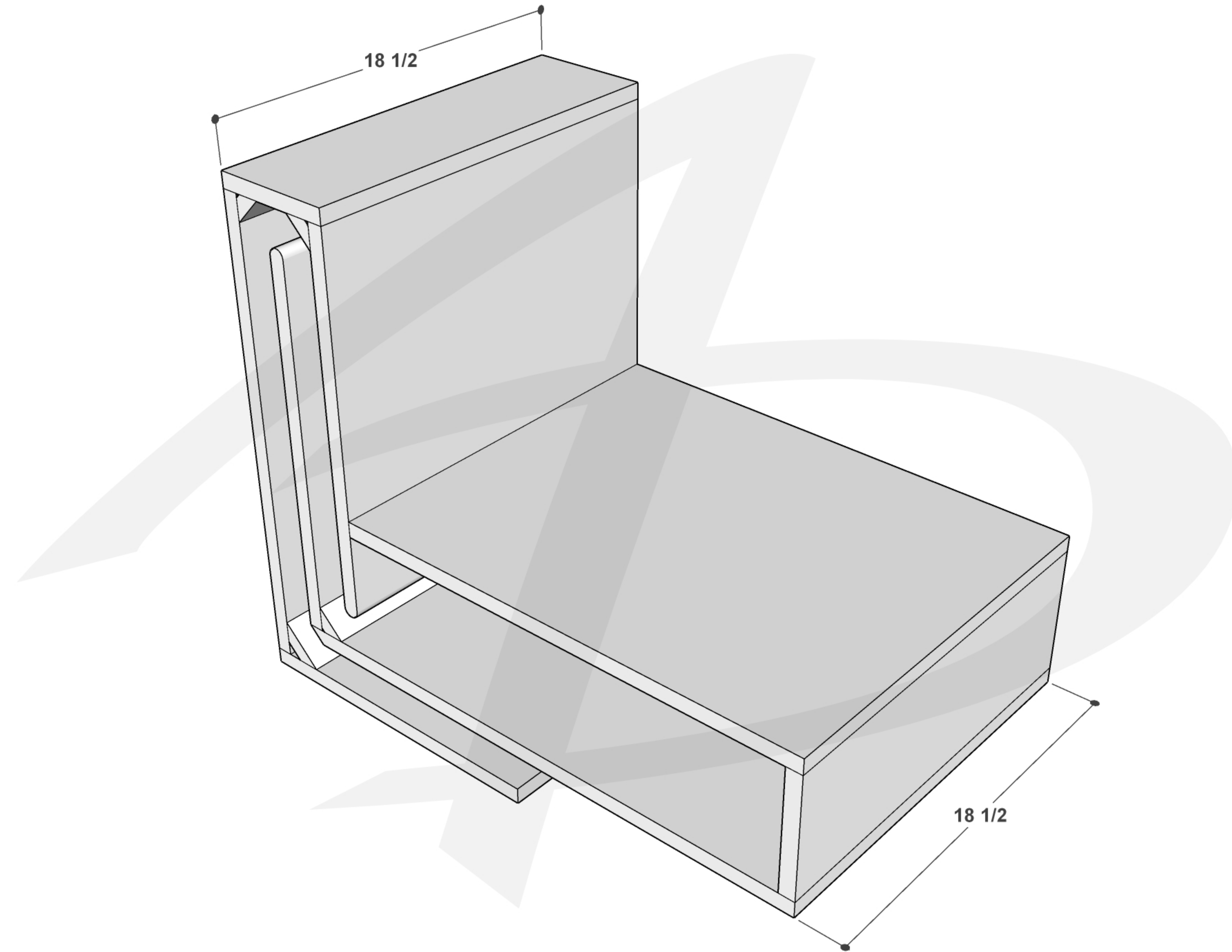

18 1/2

18 1/2

