

Vehicle Information	
Year	2018
Make	Ford
Model	F-150

Enclosure Information	
Design Type	Bass-Reflex
Placement	In place of rear seat
Orientation	Position the enclosure with the sub directed forward, vent directed upward.



**AUDIO DYNAMICS**

Special Notes

Amplifier Information	
Continuous Power Handling	2,000 W
Subsonic Filter Setting	28 Hz
Low Pass Filter Setting	60 Hz

Subwoofer Information	
Make	Audio Dynamics
Model	AD6015 D2
Quantity	1

Performance Information	
SQ	<input checked="" type="checkbox"/> Within the Vehicle
<input checked="" type="checkbox"/> SQL	Outside the Vehicle
SPL	Metering Position

Metering Information		
Headrest	Peak Frequency	Hz
Dash / Windshield		
Foot Well		

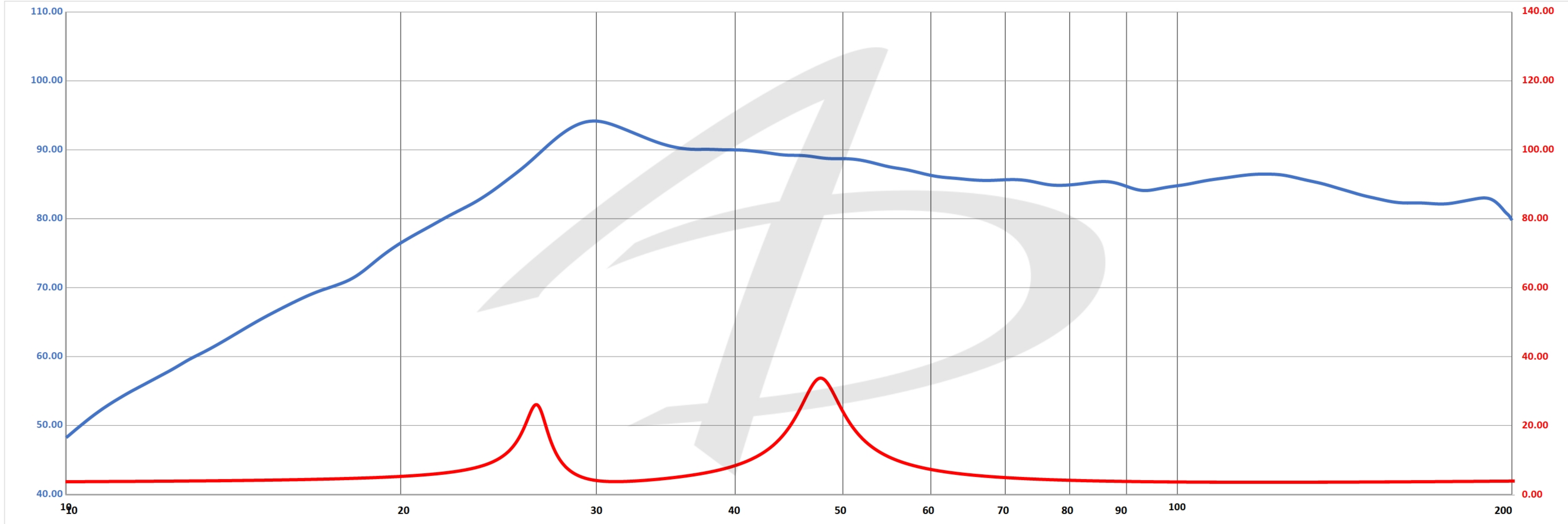

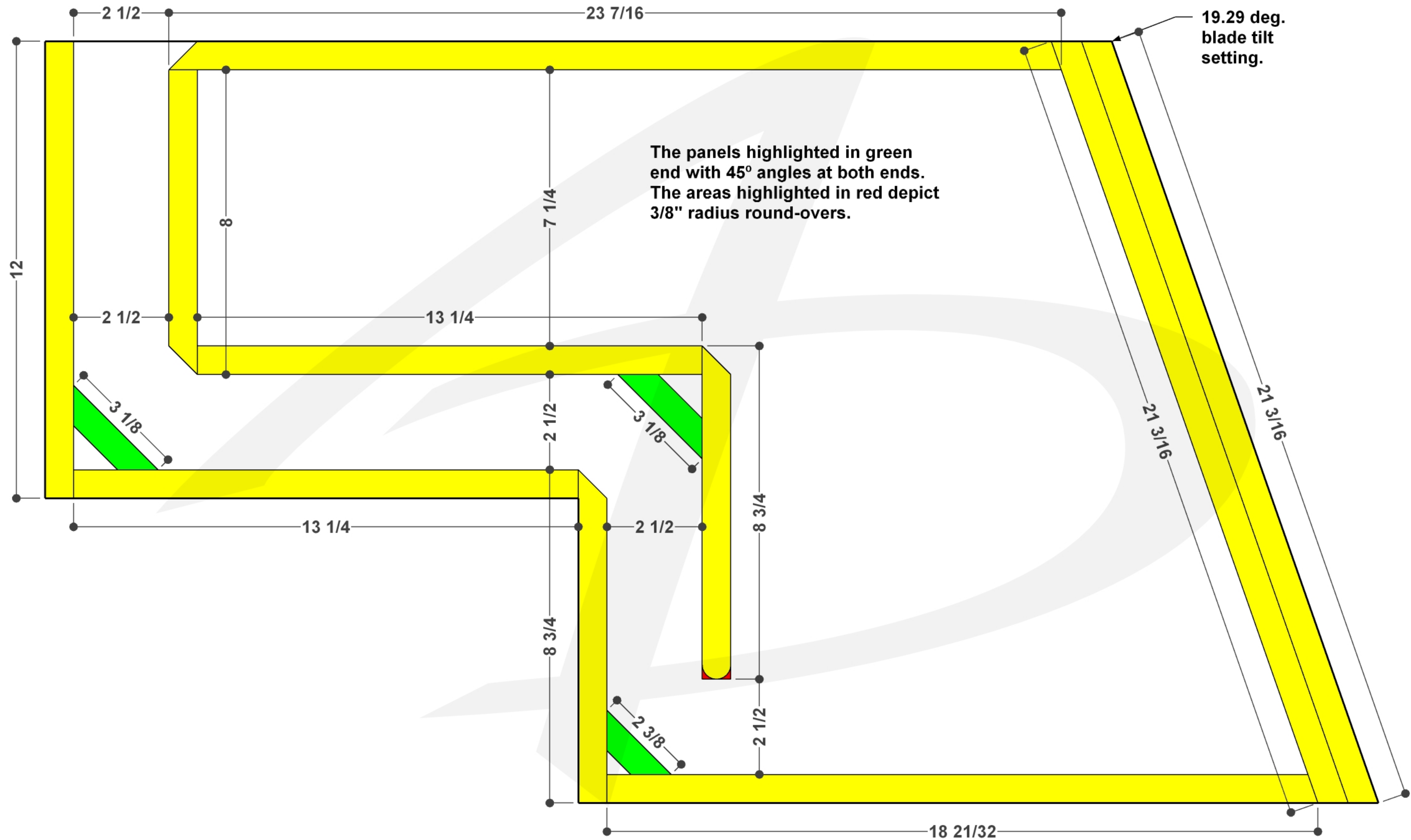

The panels highlighted in green  
 end with 45° angles at both ends.  
 The areas highlighted in red depict  
 3/8" radius round-overs.

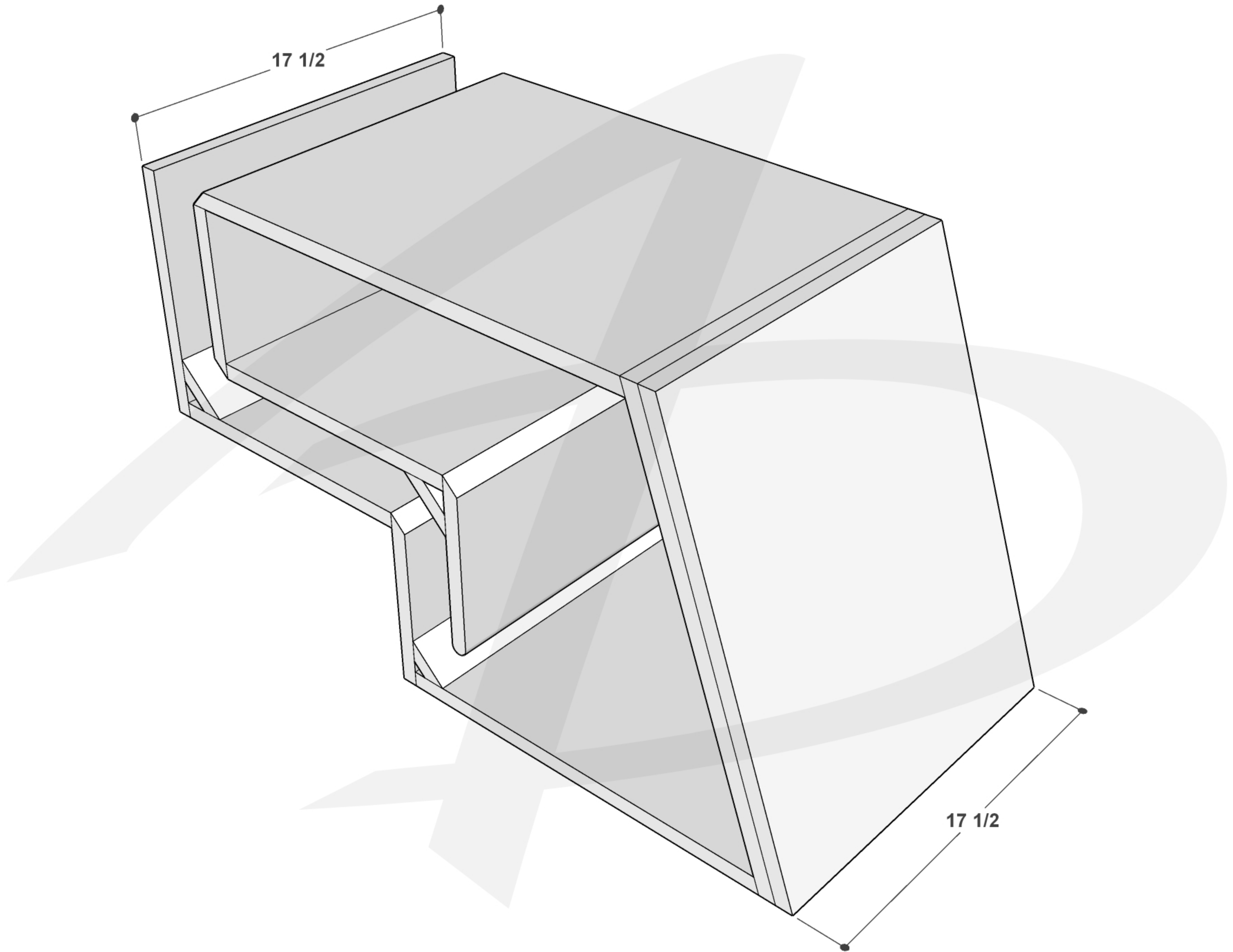

17 1/2

17 1/2

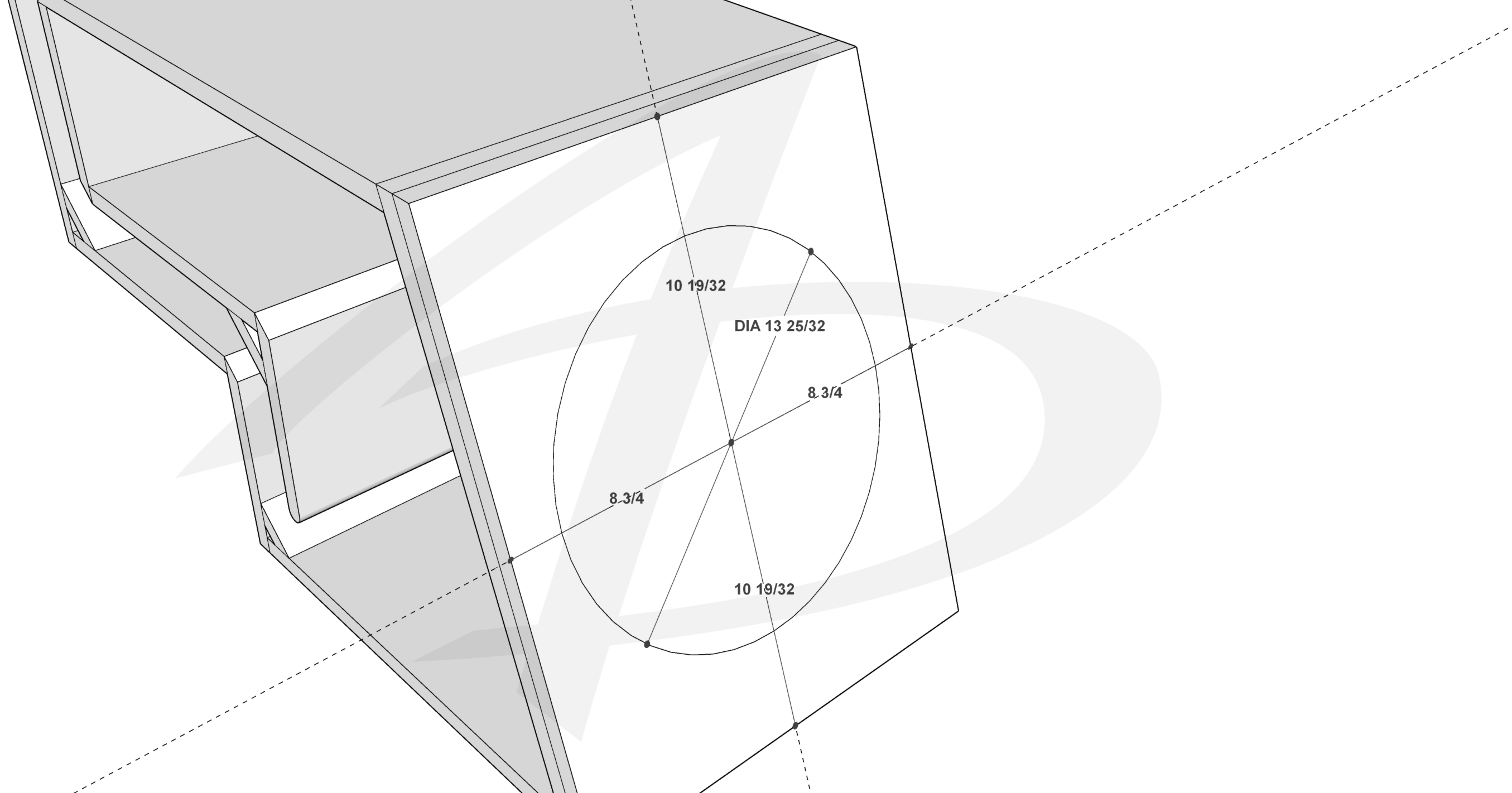

$10 \frac{19}{32}$

$\text{DIA } 13 \frac{25}{32}$

$8 \frac{3}{4}$

$8 \frac{3}{4}$

$10 \frac{19}{32}$

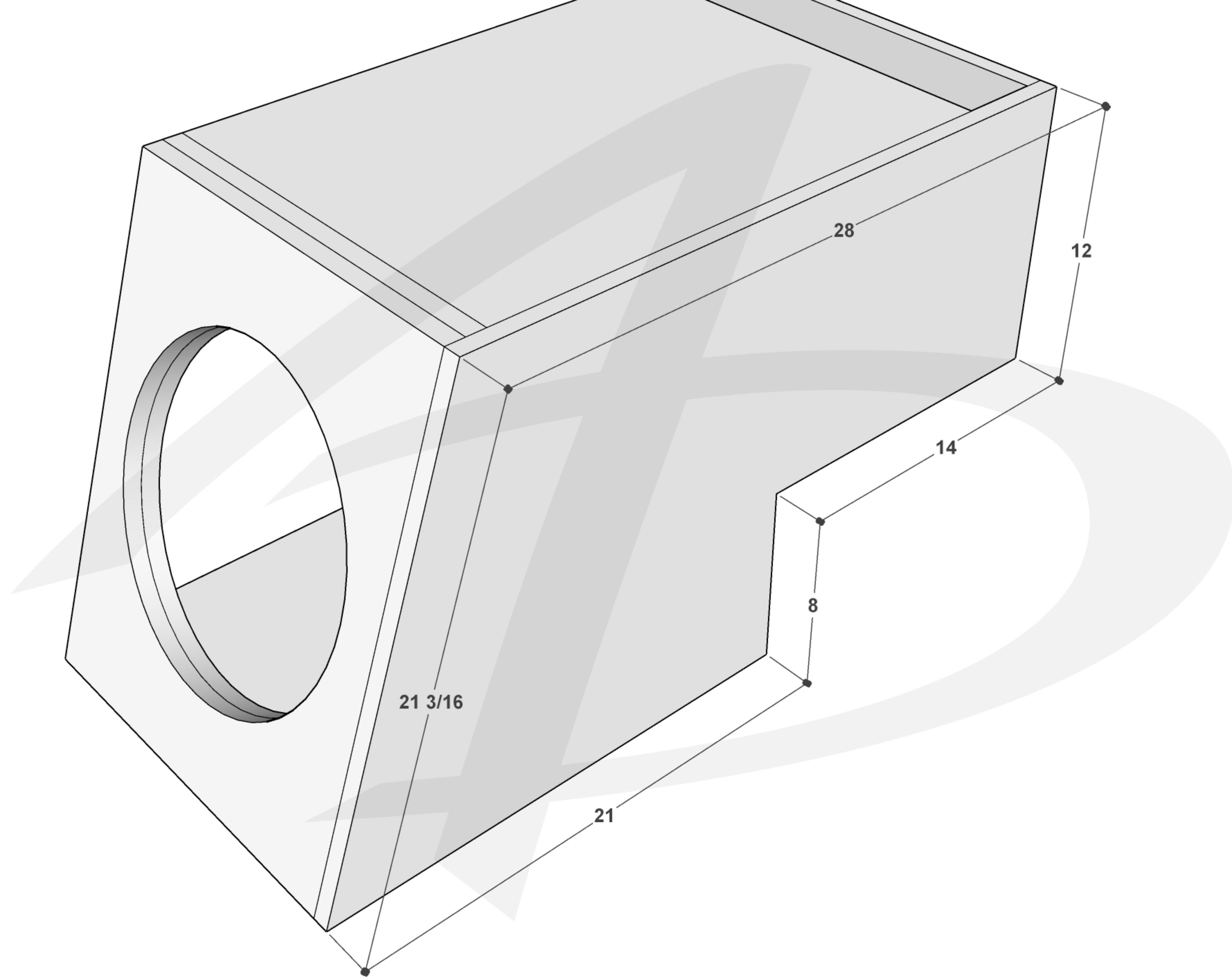

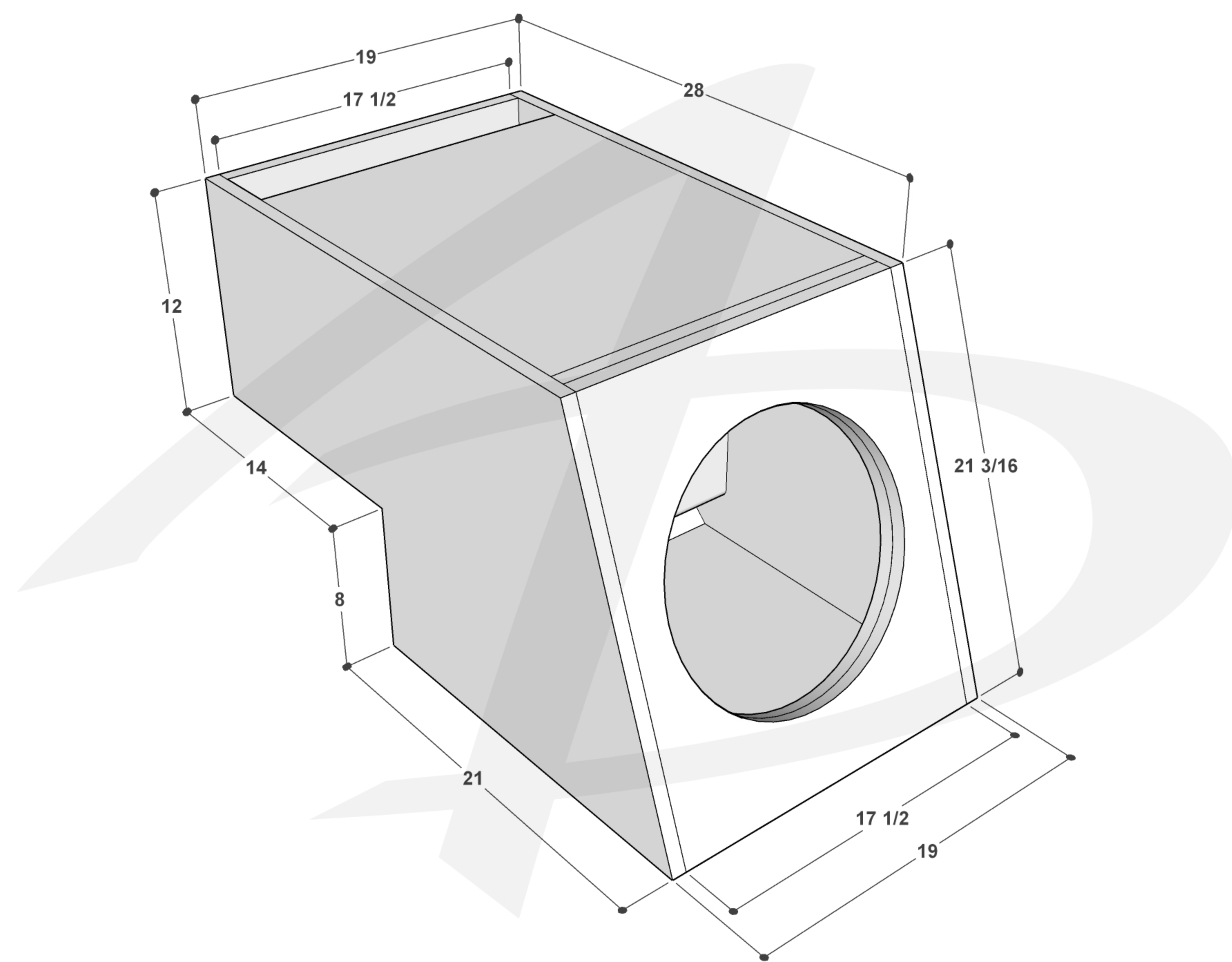

19

17 1/2

28

12

14

8

21

21 3/16

17 1/2

19

