

Vehicle Information	
Year	2013
Make	GMC
Model	Sierra 1500

Enclosure Information	
Design Type	Bass-Reflex
Placement	Under Seat
Orientation	Position the enclosure with the subs directed forward along the passenger side, vent toward the passenger side.



AUDIO DYNAMICS

Special Notes

Amplifier Information	
Continuous Power Handling	1,200 W
Subsonic Filter Setting	24 Hz
Low Pass Filter Setting	55 Hz

Subwoofer Information	
Make	Audio Dynamics
Model	AD3010 D2
Quantity	2

Performance Information	
SQ	<input checked="" type="checkbox"/> Within the Vehicle
<input checked="" type="checkbox"/> SQL	Outside the Vehicle
SPL	Metering Position

Metering Information		
Headrest	Peak Frequency	Hz
Dash / Windshield		
Foot Well		

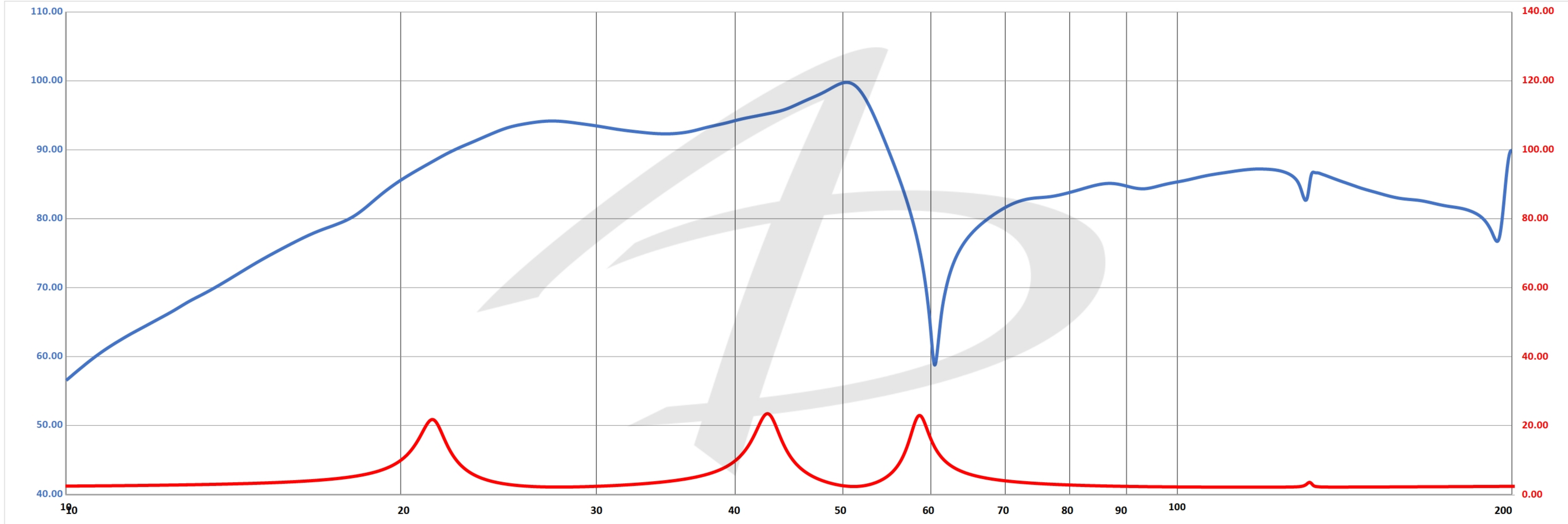

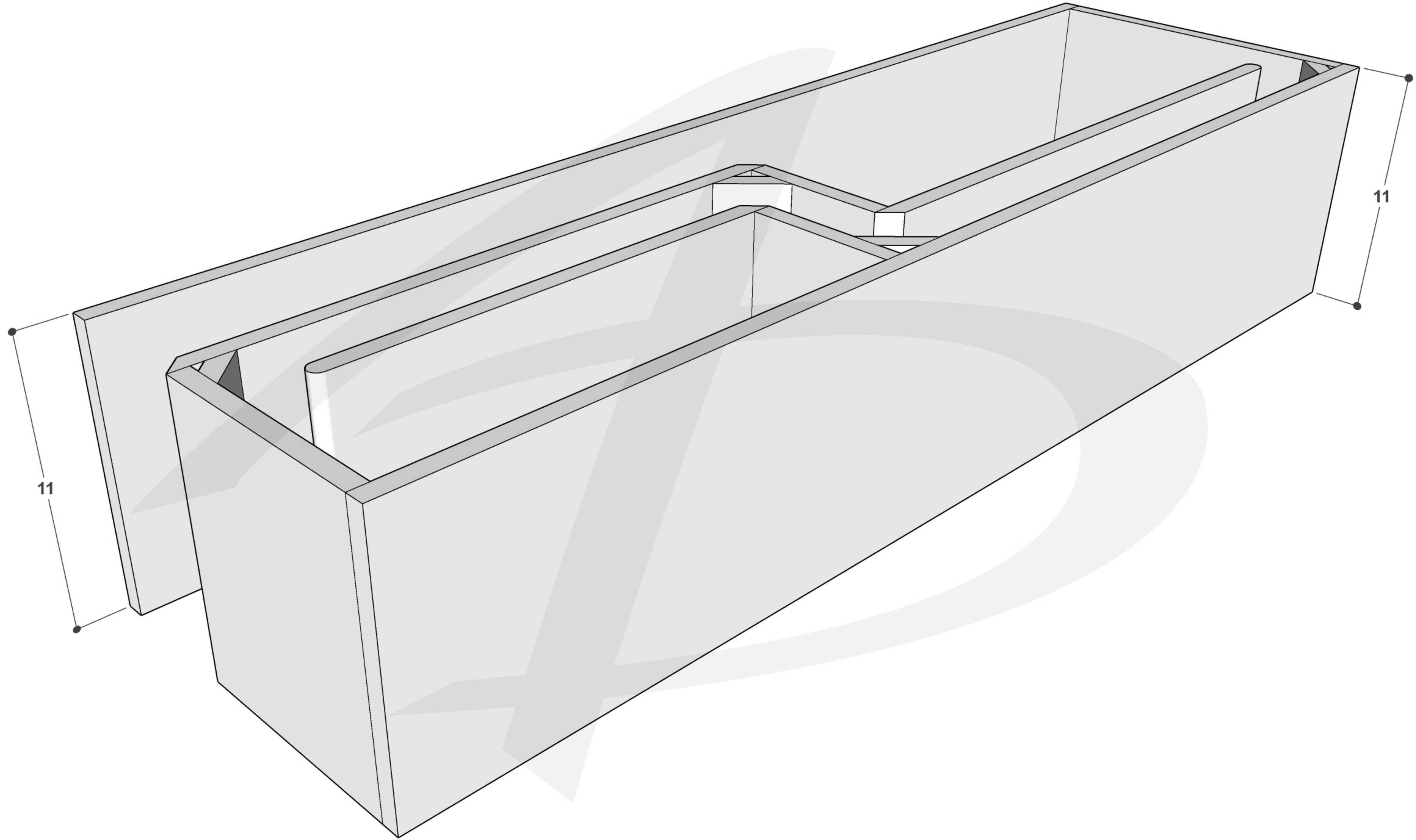

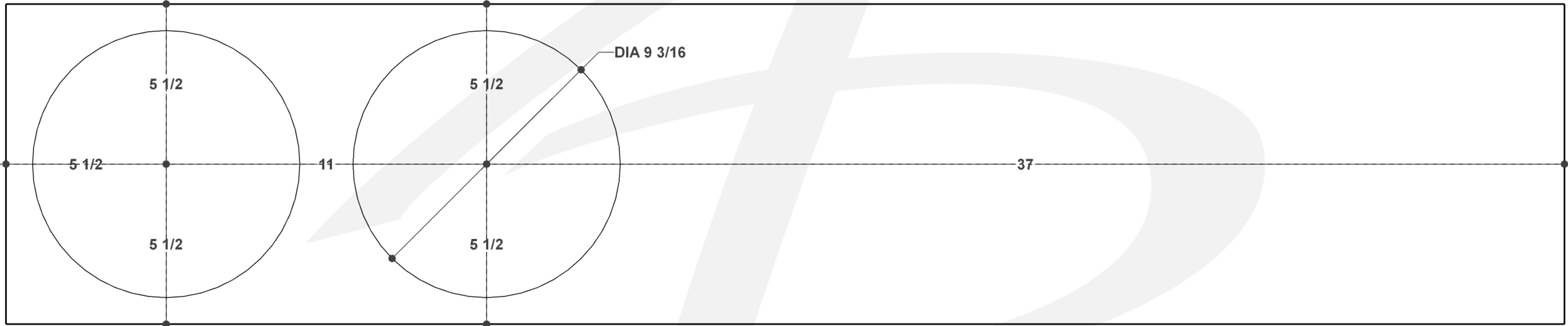

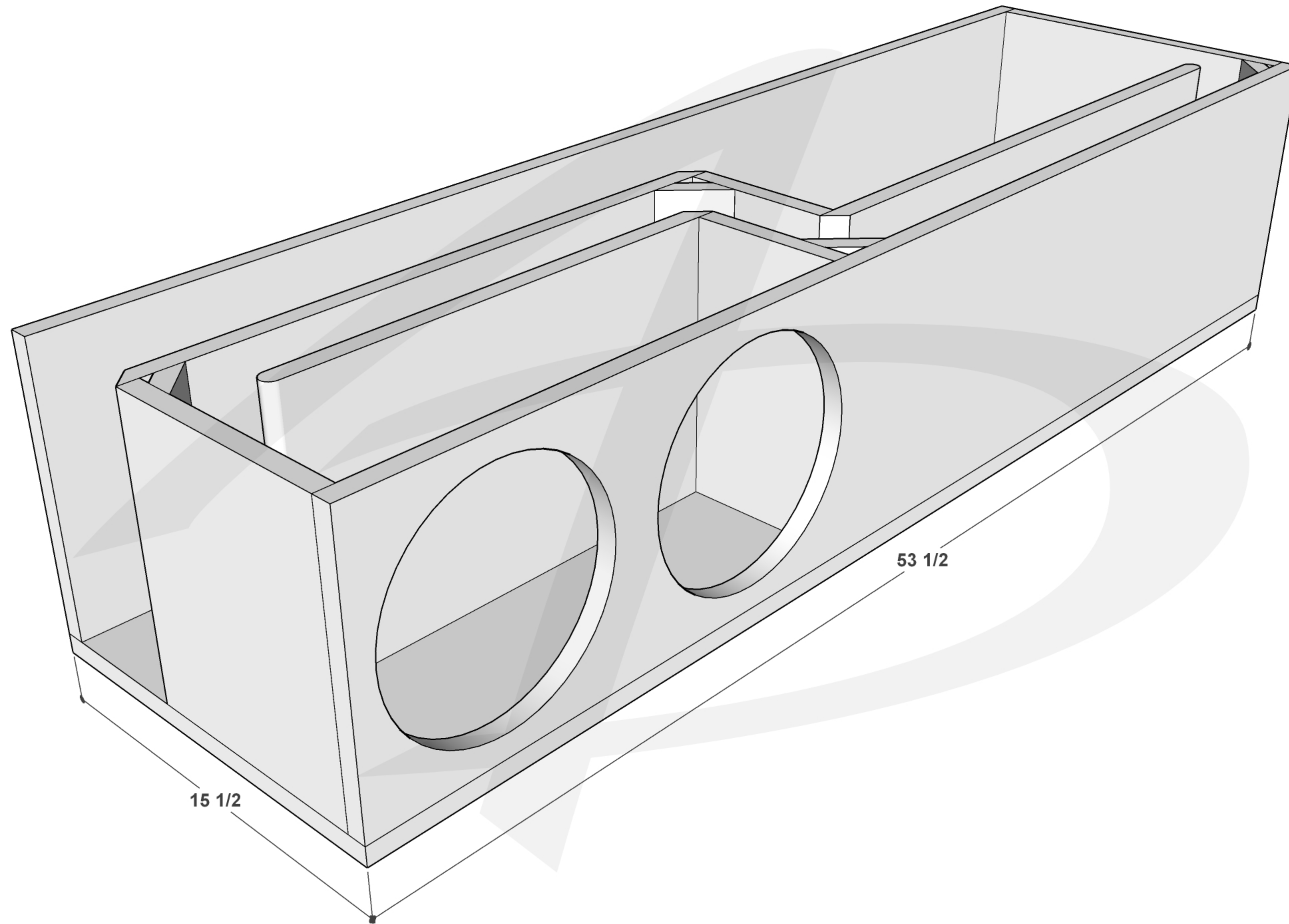

15 1/2

53 1/2

