

Vehicle Information	
Year	2024
Make	Ford
Model	F450

Enclosure Information	
Design Type	Bass-Reflex
Placement	Under rear seat
Orientation	Position the enclosure with the subs directed forward along the passenger side, vent directed toward the driver side.



AUDIO DYNAMICS

Special Notes

Amplifier Information	
Continuous Power Handling	2,400 W
Subsonic Filter Setting	24 Hz
Low Pass Filter Setting	60 Hz

Subwoofer Information	
Make	Audio Dynamics
Model	AD3008 D2
Quantity	4

Performance Information	
SQ	<input checked="" type="checkbox"/> Within the Vehicle
<input checked="" type="checkbox"/> SQL	Outside the Vehicle
SPL	Metering Position

Metering Information		
Headrest	Peak Frequency	Hz
Dash / Windshield		
Foot Well		

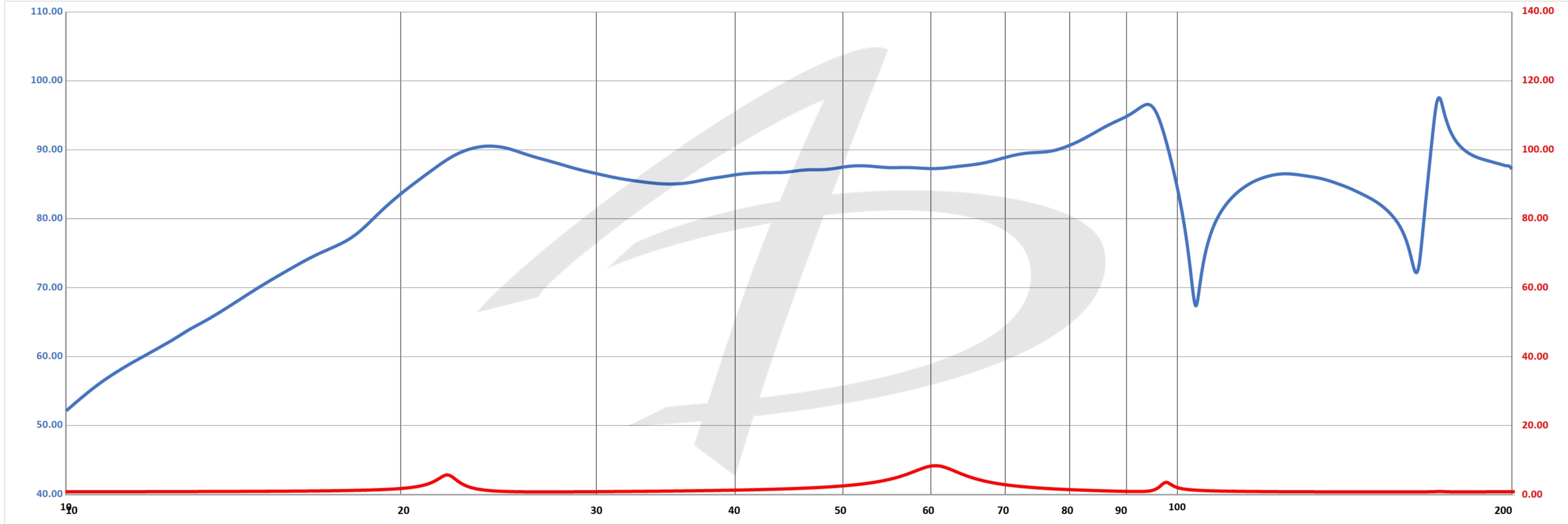

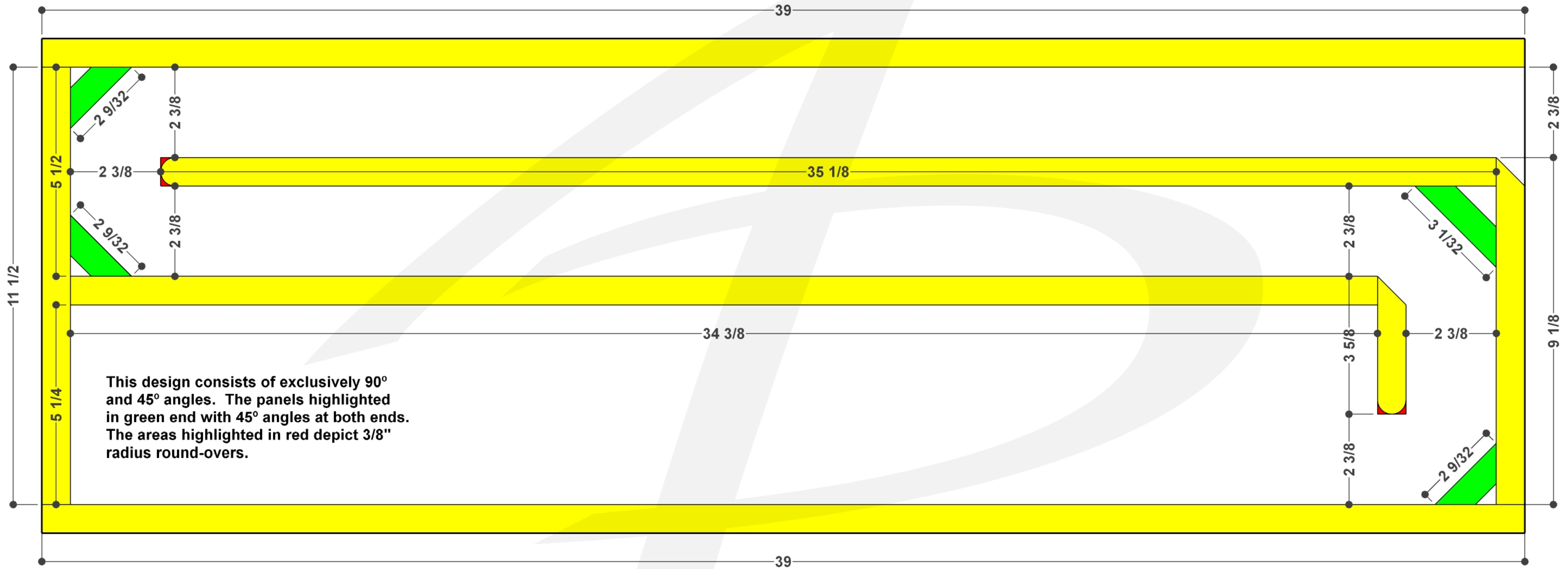

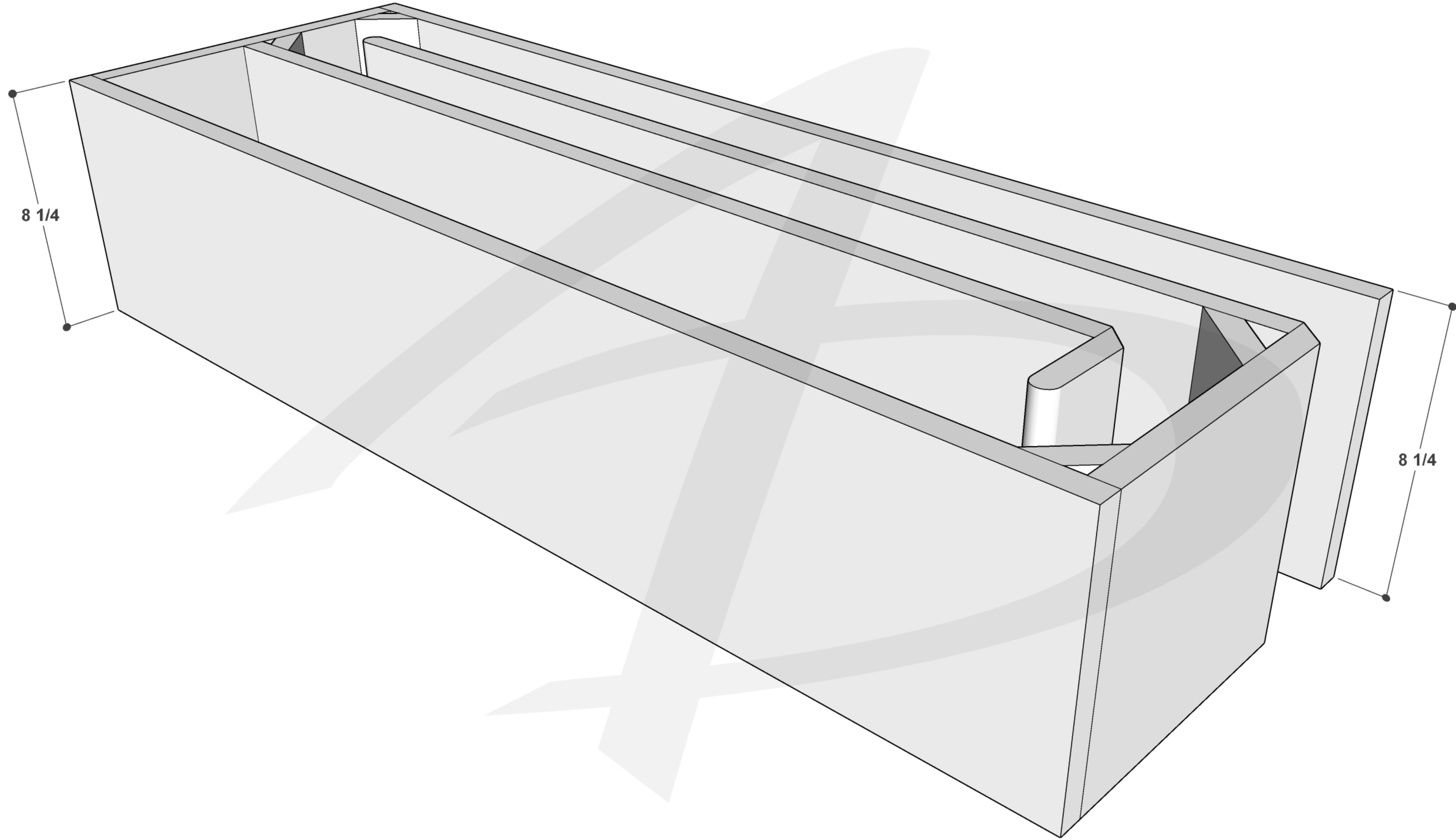

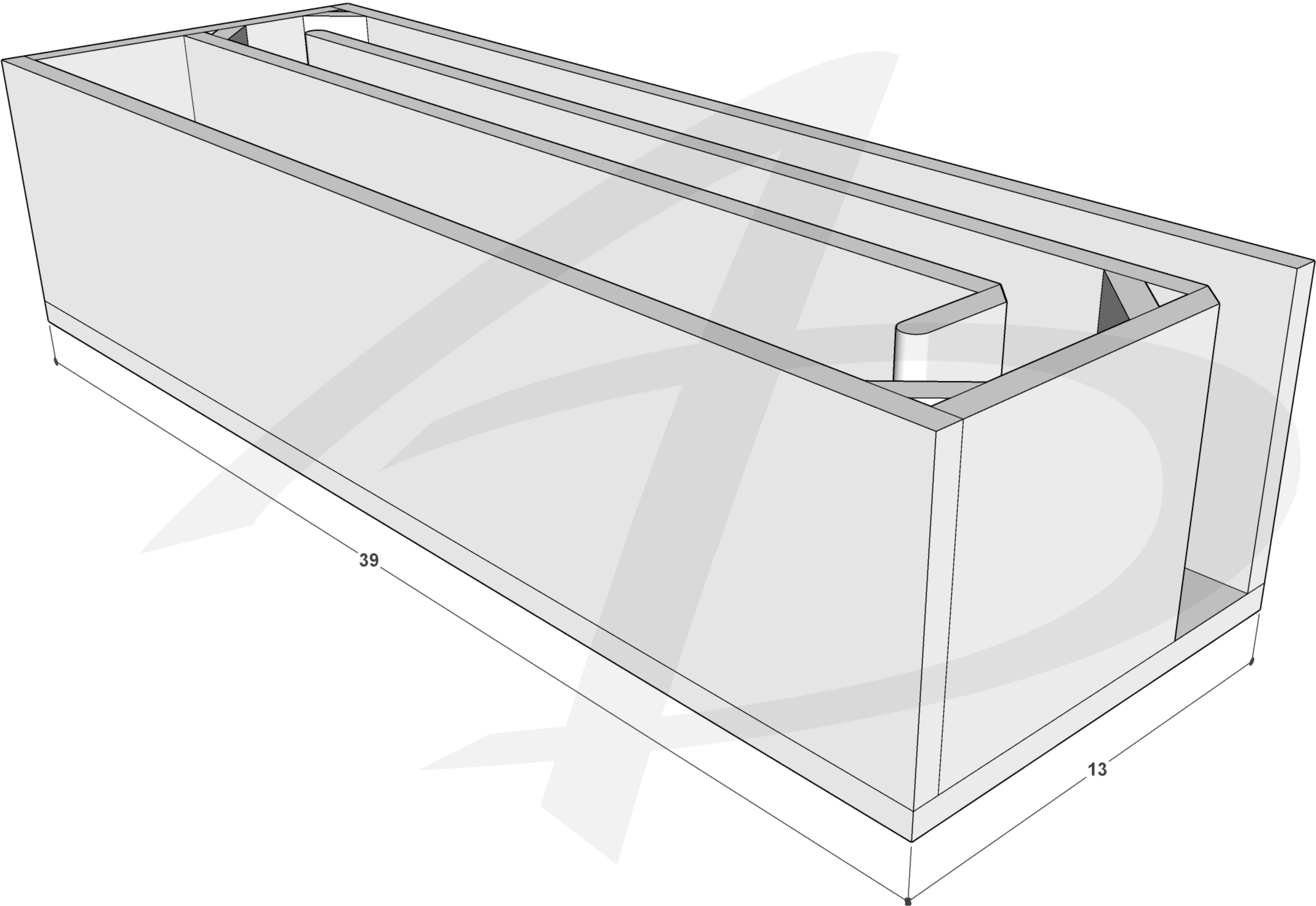

39

13

