



AUDIO DYNAMICS

Vehicle Information	
Year	2014
Make	Chevy
Model	Silverado

Enclosure Information	
Design Type	Tapped Horn
Placement	In place of rear seats
Orientation	Position the enclosure with the mouth of the horn directed toward the driver side along the floor.

Special Notes
The driver mounts inverted. As such, mind the tight motor clearance when installing or removing the sub.

Amplifier Information	
Continuous Power Handling	1,500 W
Subsonic Filter Setting	28 Hz
Low Pass Filter Setting	70 Hz

Subwoofer Information	
Make	Audio Dynamics
Model	AD5010 D2
Quantity	1

Performance Information	
SQ	<input checked="" type="checkbox"/> Within the Vehicle
<input checked="" type="checkbox"/> SQL	Outside the Vehicle
SPL	Metering Position

Metering Information		
Headrest	Peak Frequency	Hz
Dash / Windshield		
Foot Well		

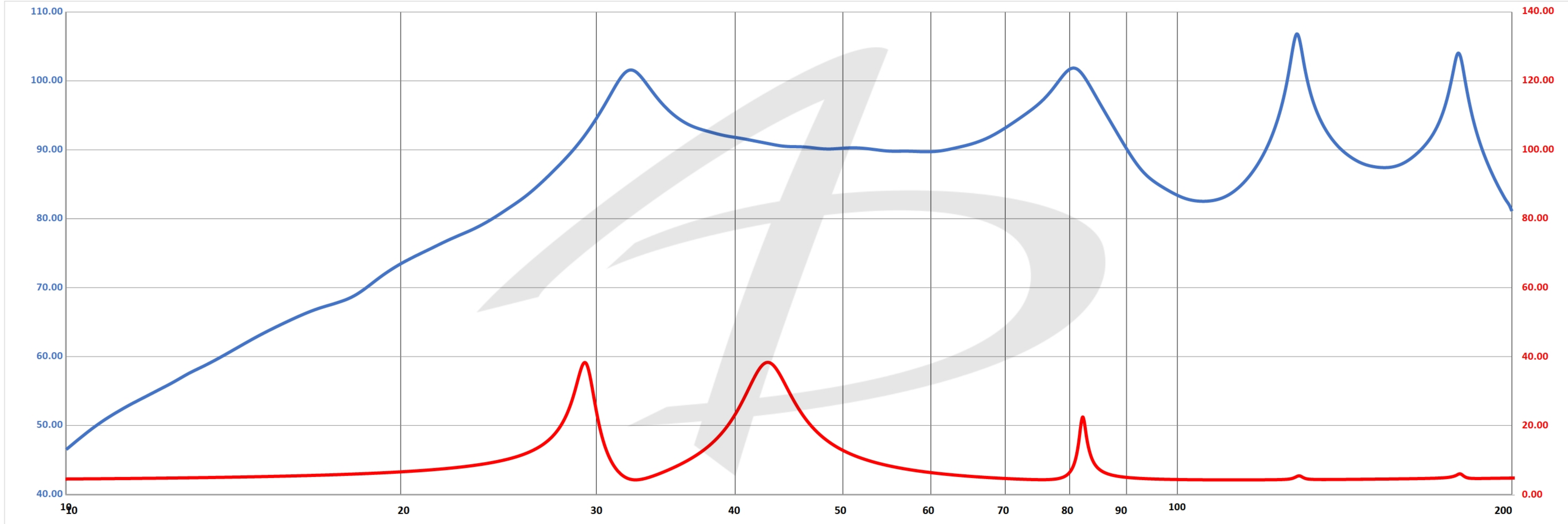

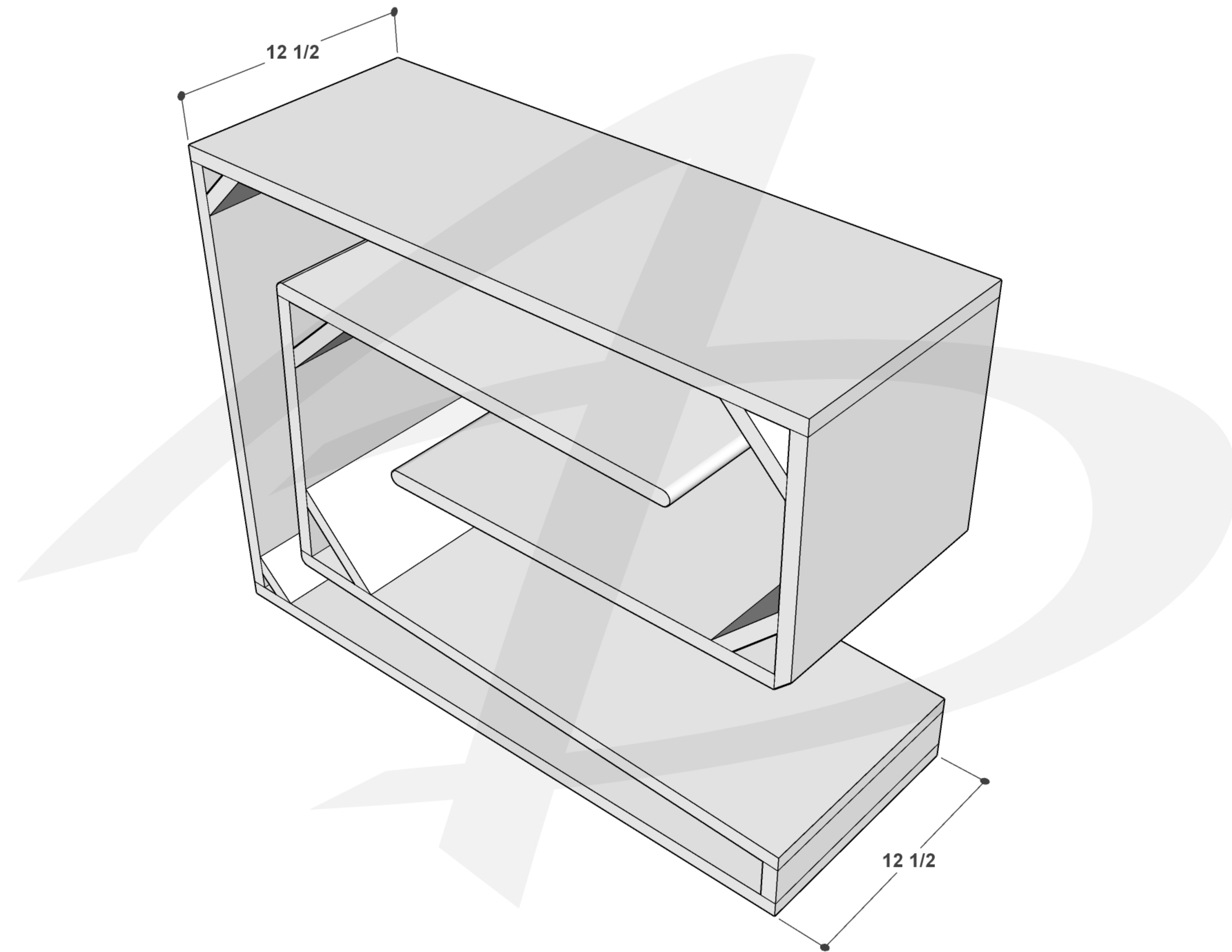

12 1/2

12 1/2

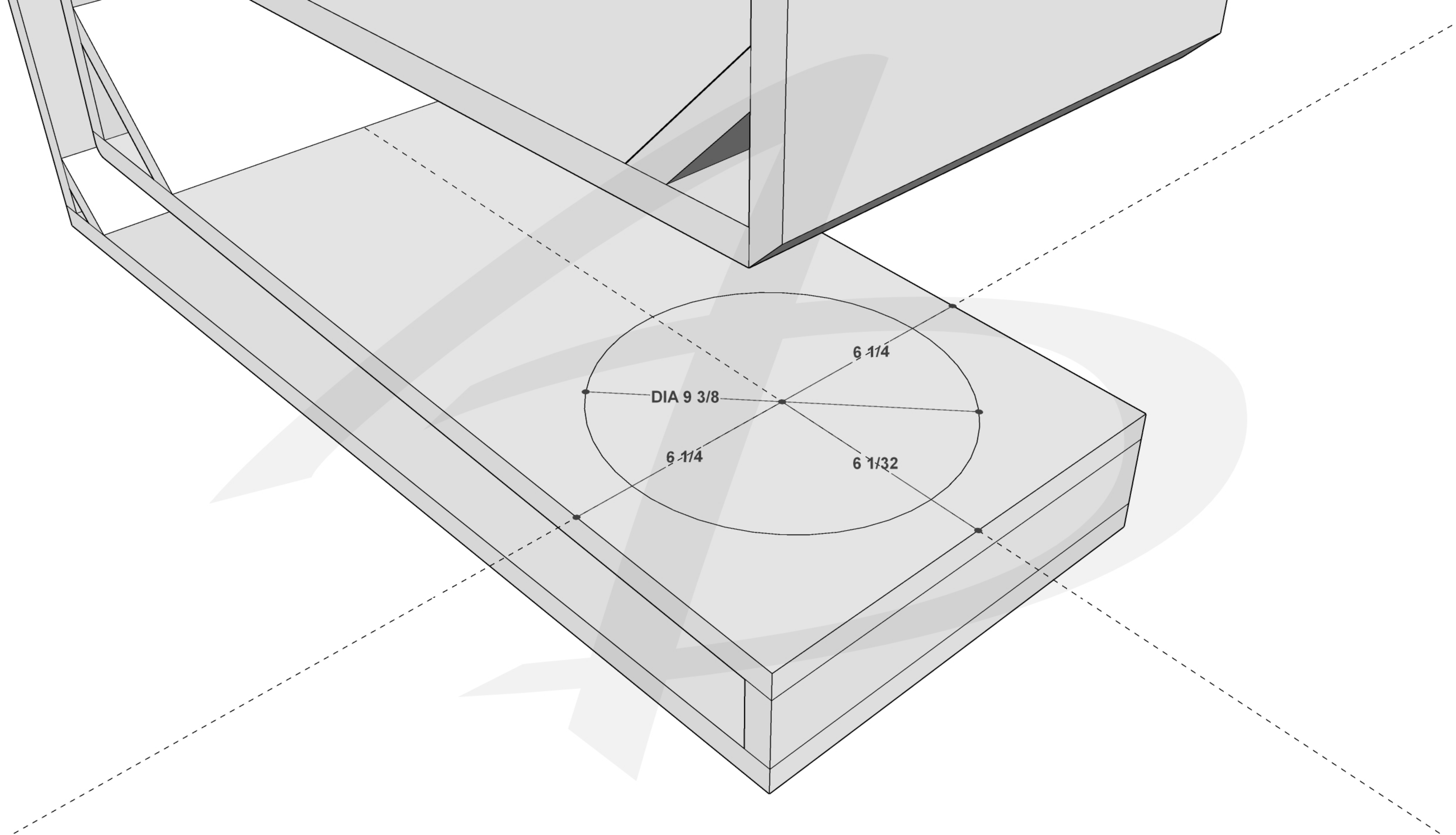

DIA 9 3/8

6 1/4

6 1/4

6 1/32

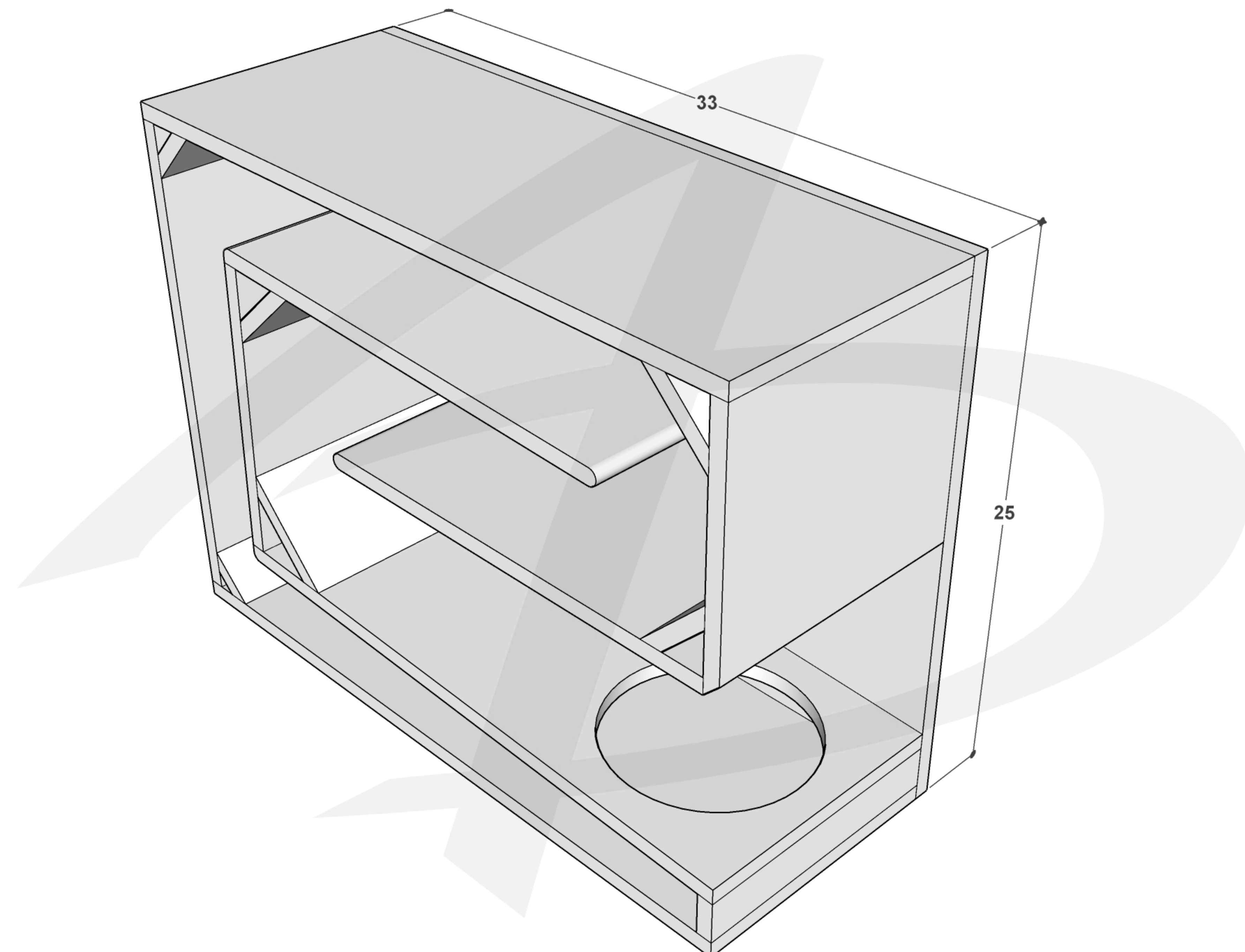

33

25

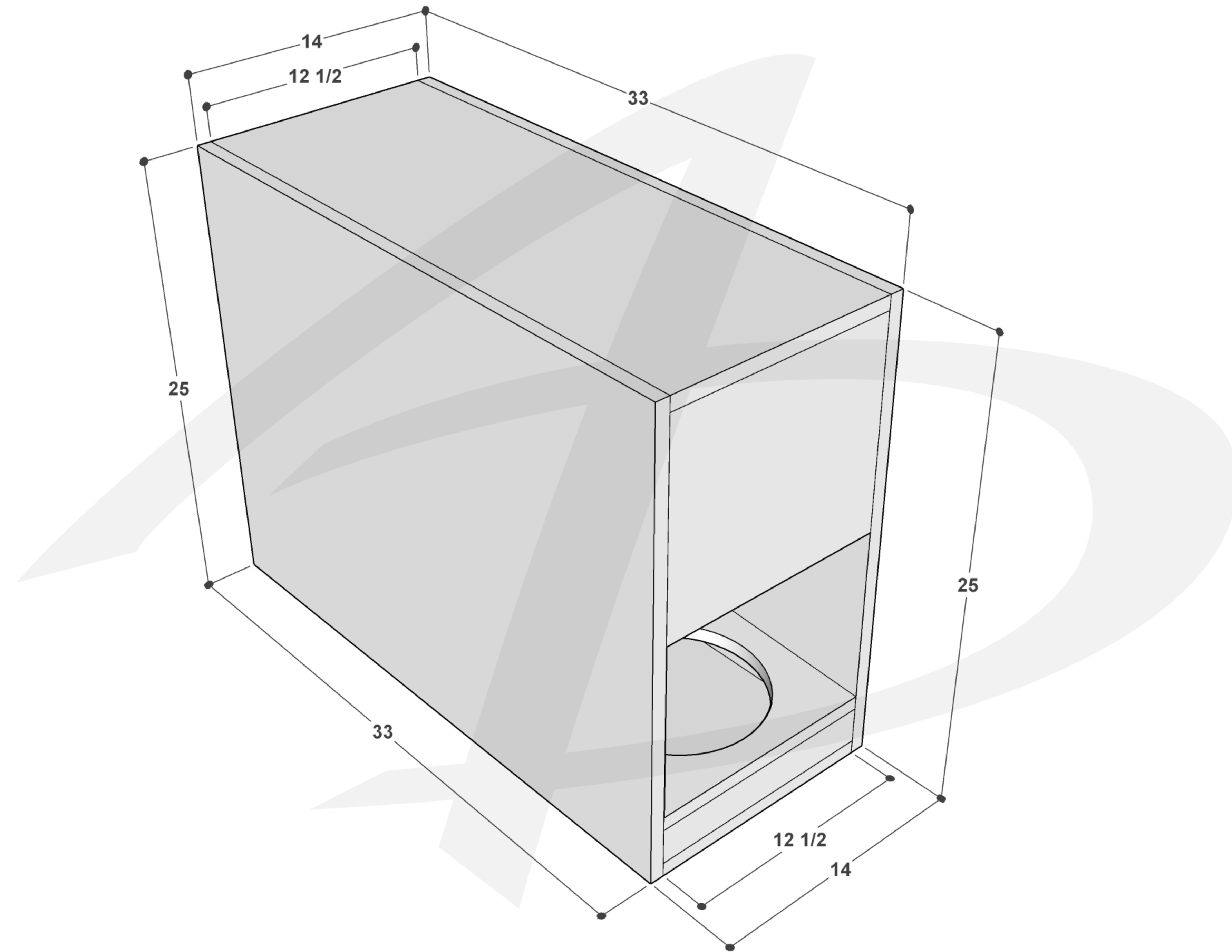

14

12 1/2

33

25

25

33

12 1/2

14

