

| Vehicle Information | |
|---------------------|---------------------|
| Year | 1965 |
| Make | Cadillac |
| Model | Deville Convertible |

| Enclosure Information | |
|-----------------------|---|
| Design Type | Bass-Reflex |
| Placement | Trunk |
| Orientation | Position the enclosure along the driver or passenger side, with the driver directed rearward, vent along the floor. |



AUDIO DYNAMICS

| Special Notes |
|---------------|
| |

| Amplifier Information | |
|---------------------------|-------|
| Continuous Power Handling | 600 W |
| Subsonic Filter Setting | 28 Hz |
| Low Pass Filter Setting | 60 Hz |

| Subwoofer Information | |
|-----------------------|----------------|
| Make | Audio Dynamics |
| Model | AD3010 D4 |
| Quantity | 1 |

| Performance Information | |
|---|--|
| SQ | <input checked="" type="checkbox"/> Within the Vehicle |
| <input checked="" type="checkbox"/> SQL | Outside the Vehicle |
| SPL | Metering Position |

| Metering Information | | |
|----------------------|----------------|----|
| Headrest | Peak Frequency | Hz |
| Dash / Windshield | | |
| Foot Well | | |

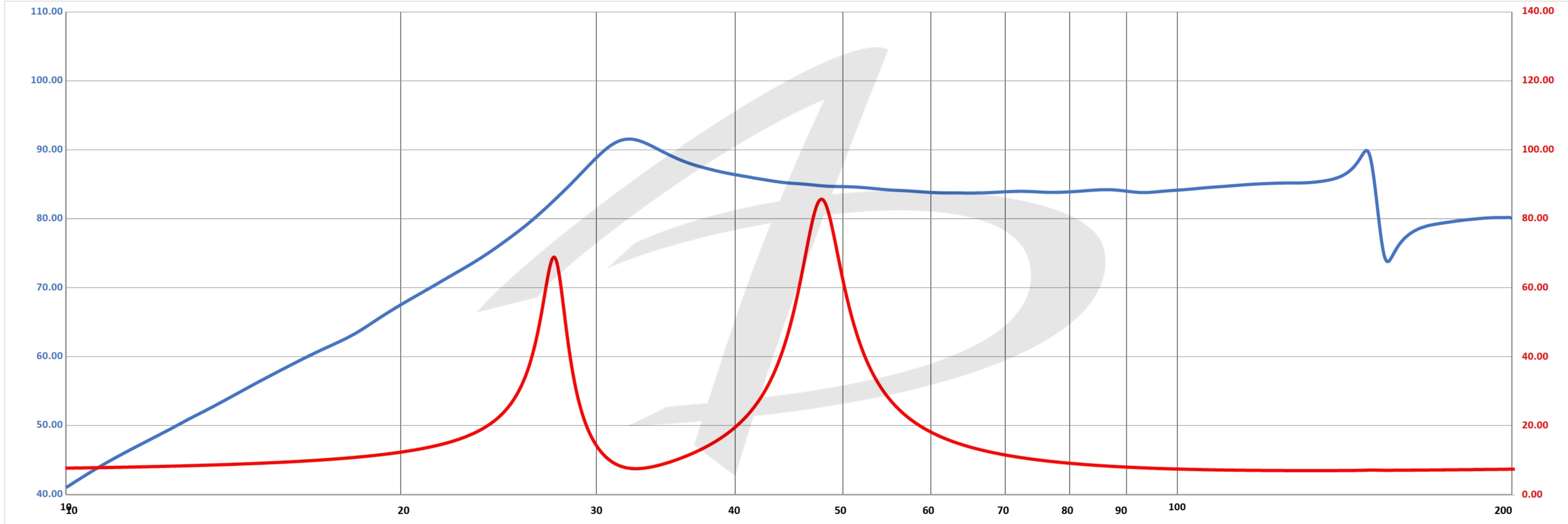

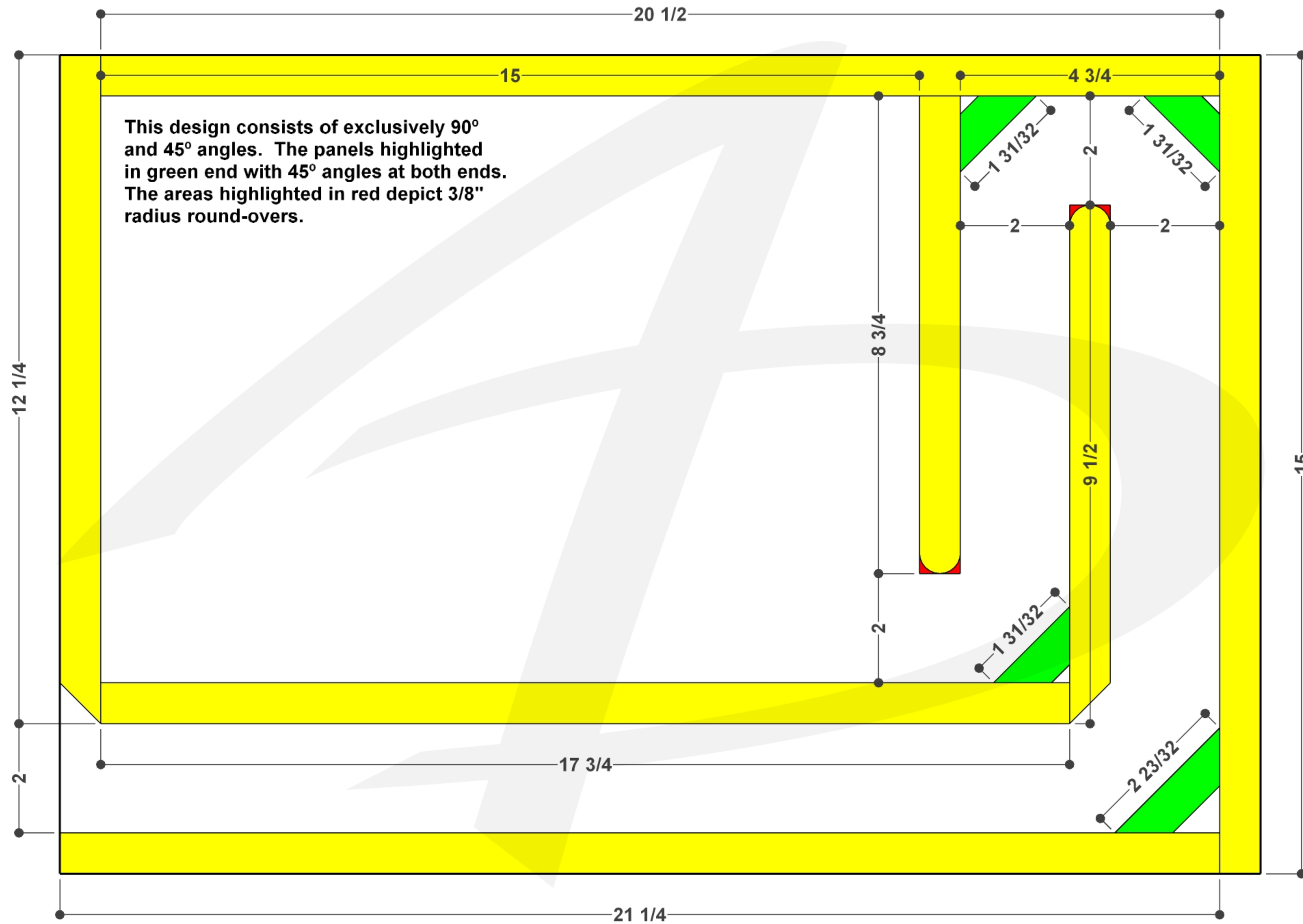

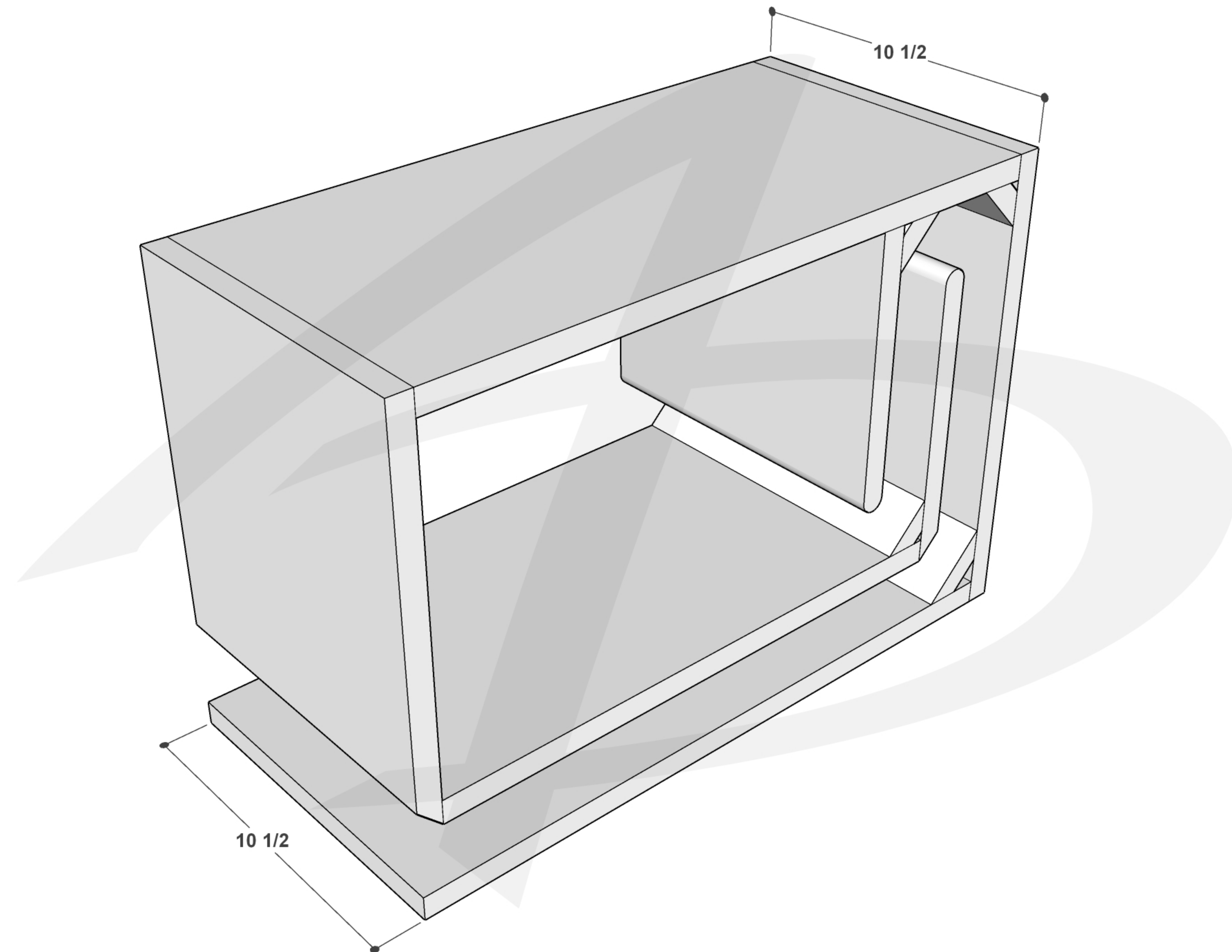

10 1/2

10 1/2

