

Vehicle Information	
Year	2005
Make	Honda
Model	Pilot

Enclosure Information	
Design Type	Bass-Reflex
Placement	Cargo area
Orientation	Position the enclosure with the subs directed rearward, vent directed toward the passenger side.



AUDIO DYNAMICS

Special Notes

Amplifier Information	
Continuous Power Handling	3,000 W
Subsonic Filter Setting	25 Hz
Low Pass Filter Setting	65 Hz

Subwoofer Information	
Make	Audio Dynamics
Model	AD5015 D4
Quantity	2

Performance Information	
✓ SQ	✓ Within the Vehicle
SQL	Outside the Vehicle
SPL	Metering Position

Metering Information		
Headrest	Peak Frequency	Hz
Dash / Windshield		
Foot Well		

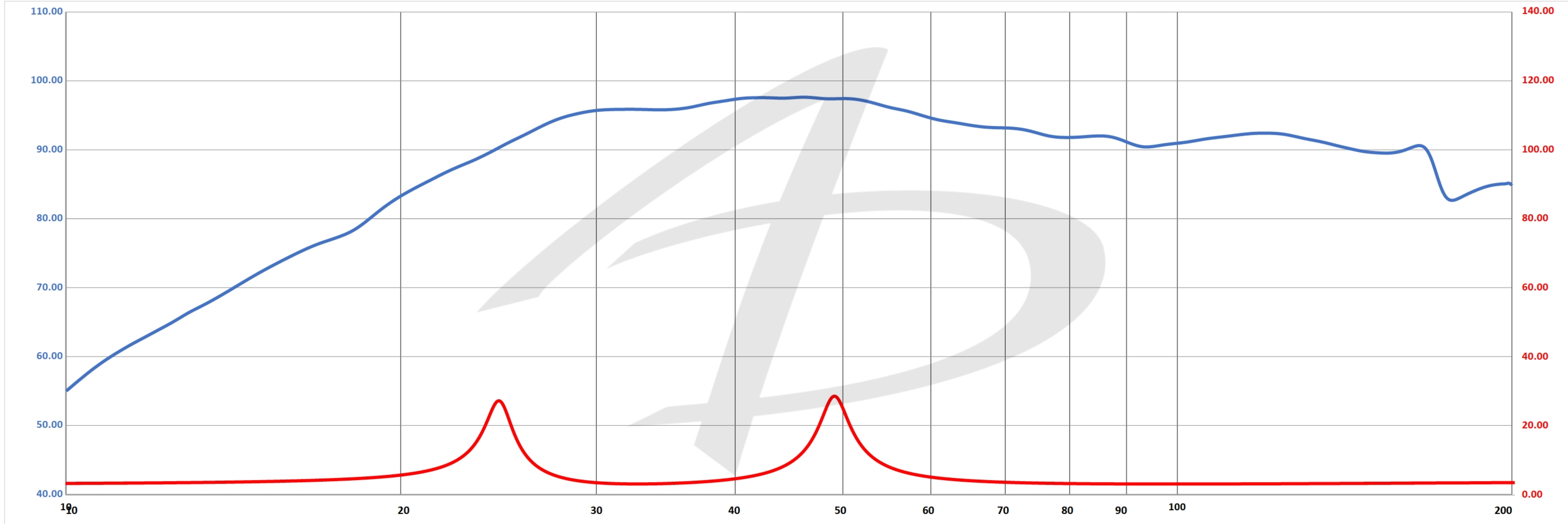

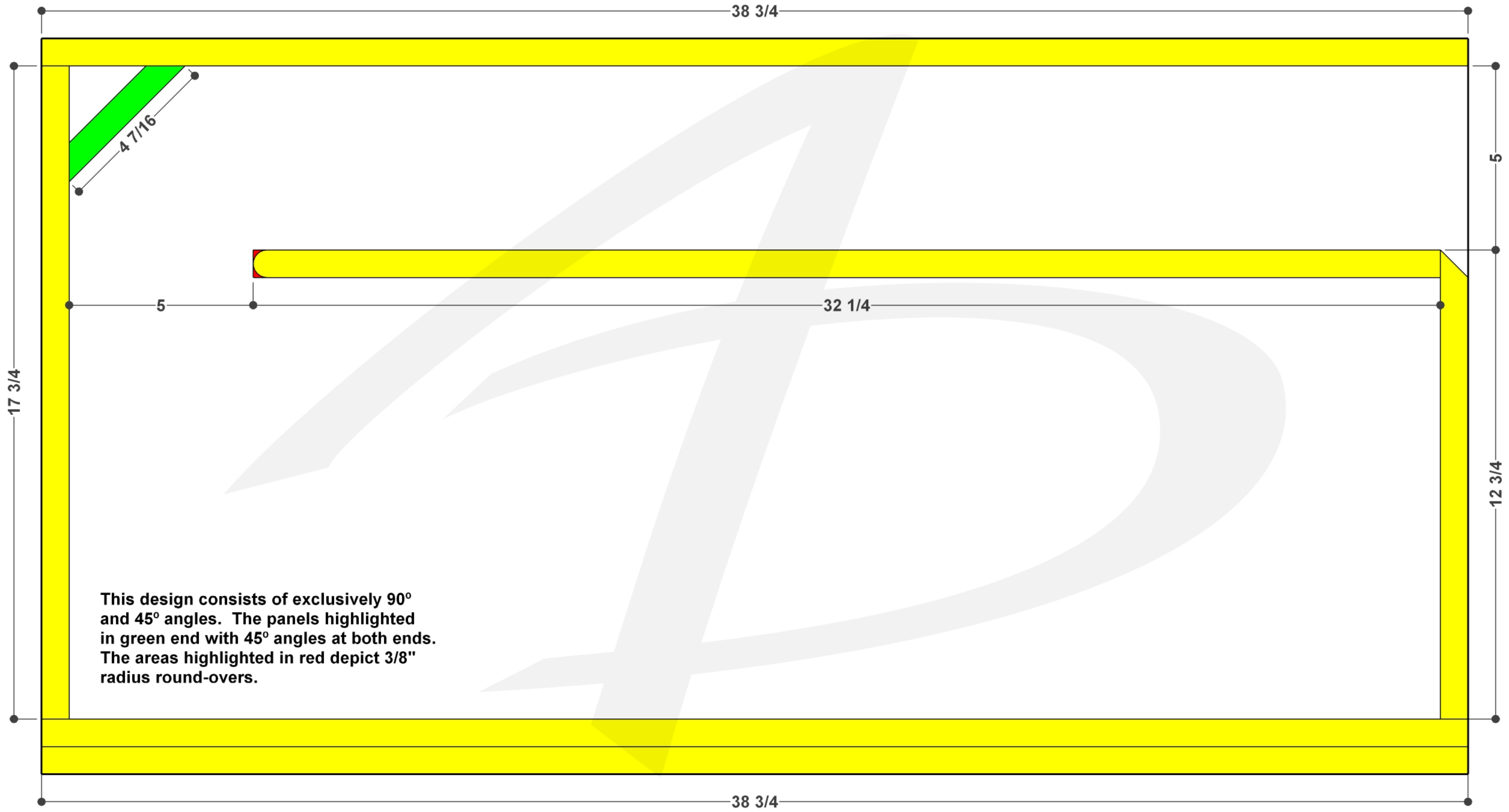

This design consists of exclusively 90° and 45° angles. The panels highlighted in green end with 45° angles at both ends. The areas highlighted in red depict $\frac{3}{8}$ " radius round-overs.

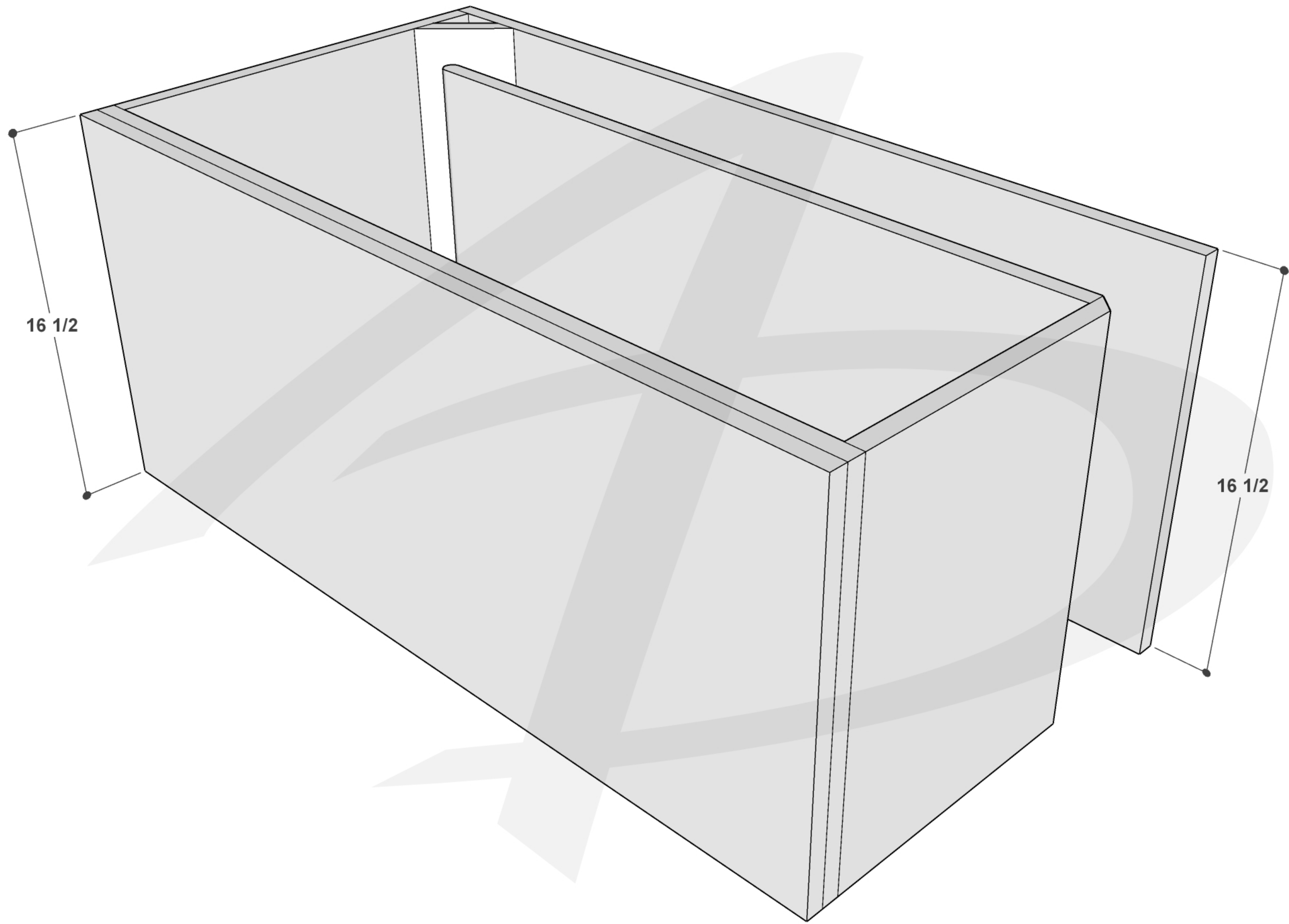

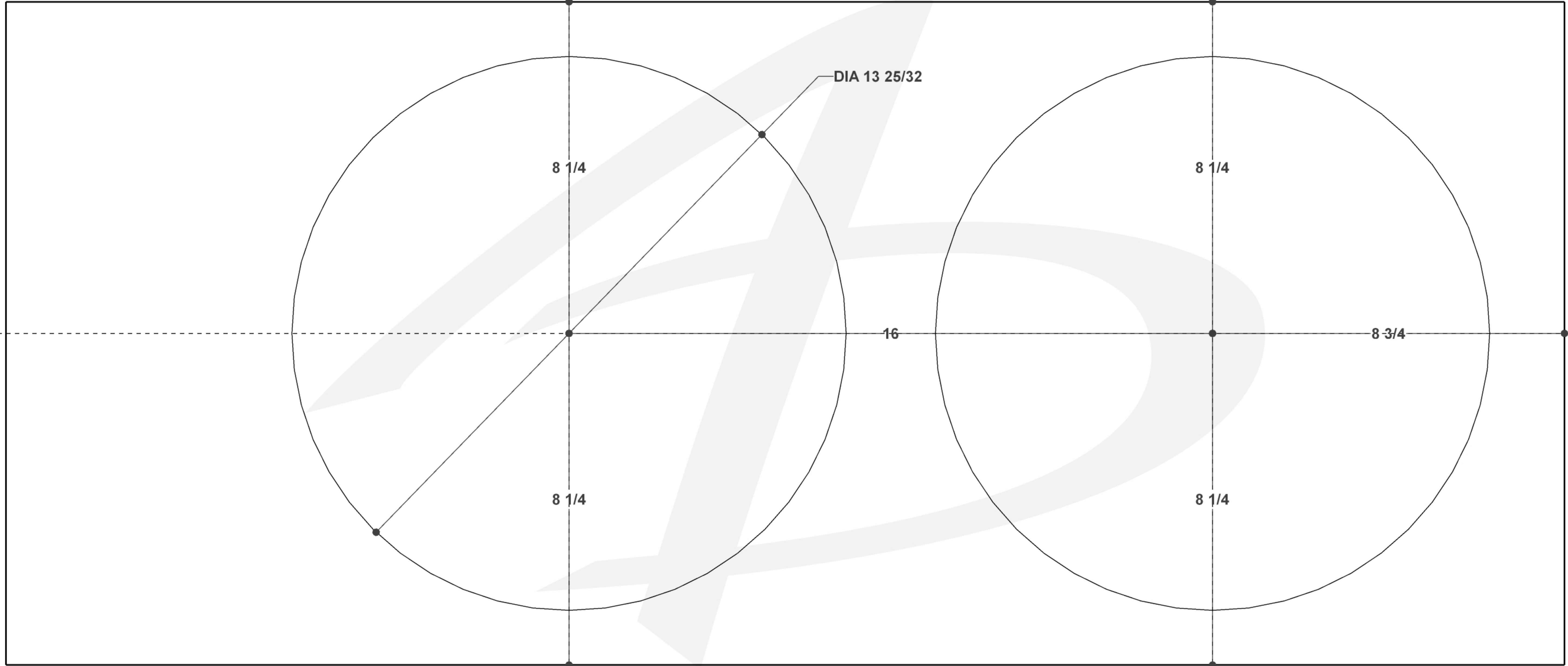

8 1/4

DIA 13 25/32

8 1/4

16

8 3/4

8 1/4

8 1/4

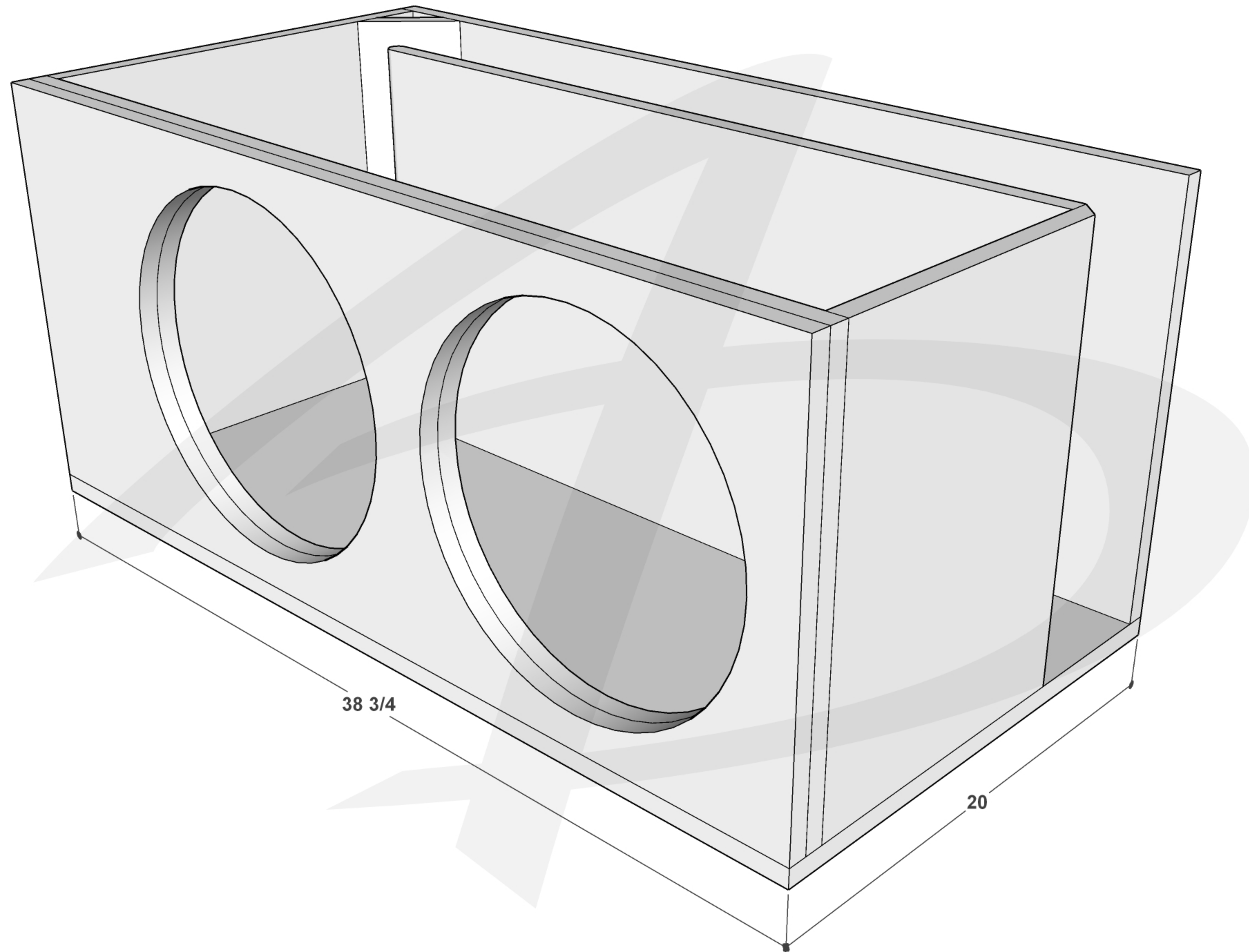

$38 \frac{3}{4}$

20

