



AUDIO DYNAMICS

Vehicle Information	
Year	2006
Make	GMC
Model	H2 Hummer

Enclosure Information	
Design Type	Bass-Reflex
Placement	Cargo area
Orientation	Position the enclosure with the subs directed rearward.

Special Notes

Amplifier Information	
Continuous Power Handling	1,200 W
Subsonic Filter Setting	24 Hz
Low Pass Filter Setting	60 Hz

Subwoofer Information	
Make	Audio Dynamics
Model	AD3015 D4
Quantity	2

Performance Information	
✓ SQ	✓ Within the Vehicle
SQL	Outside the Vehicle
SPL	Metering Position

Metering Information		
Headrest	Peak Frequency	Hz
Dash / Windshield		
Foot Well		

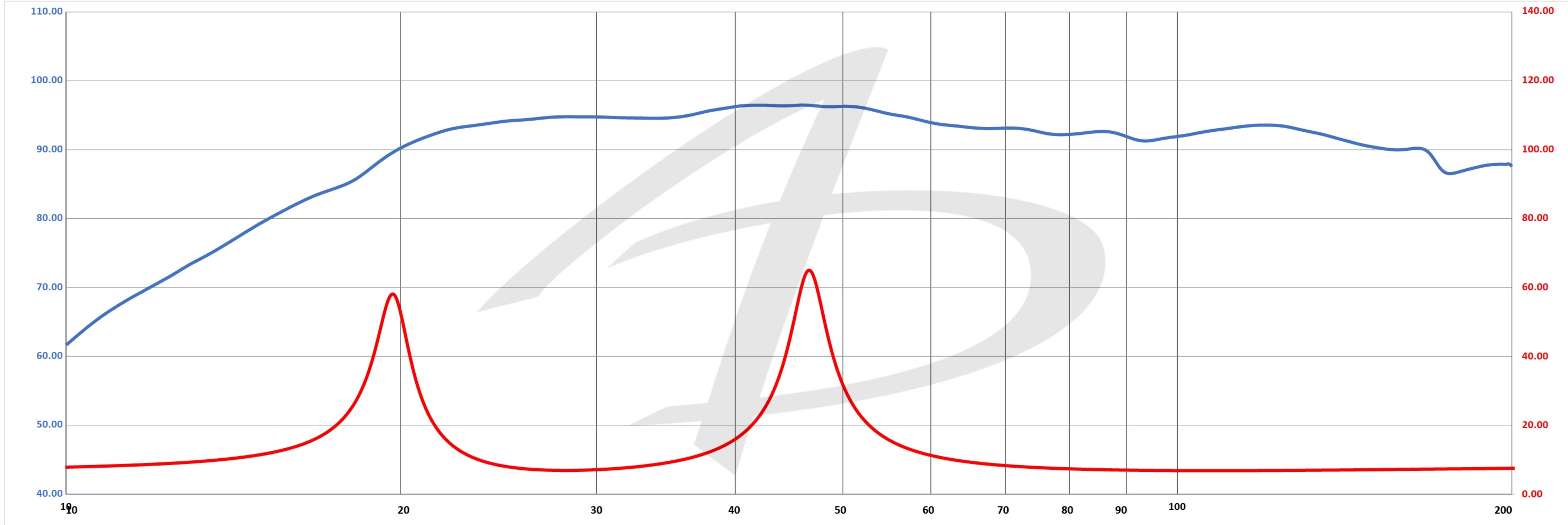

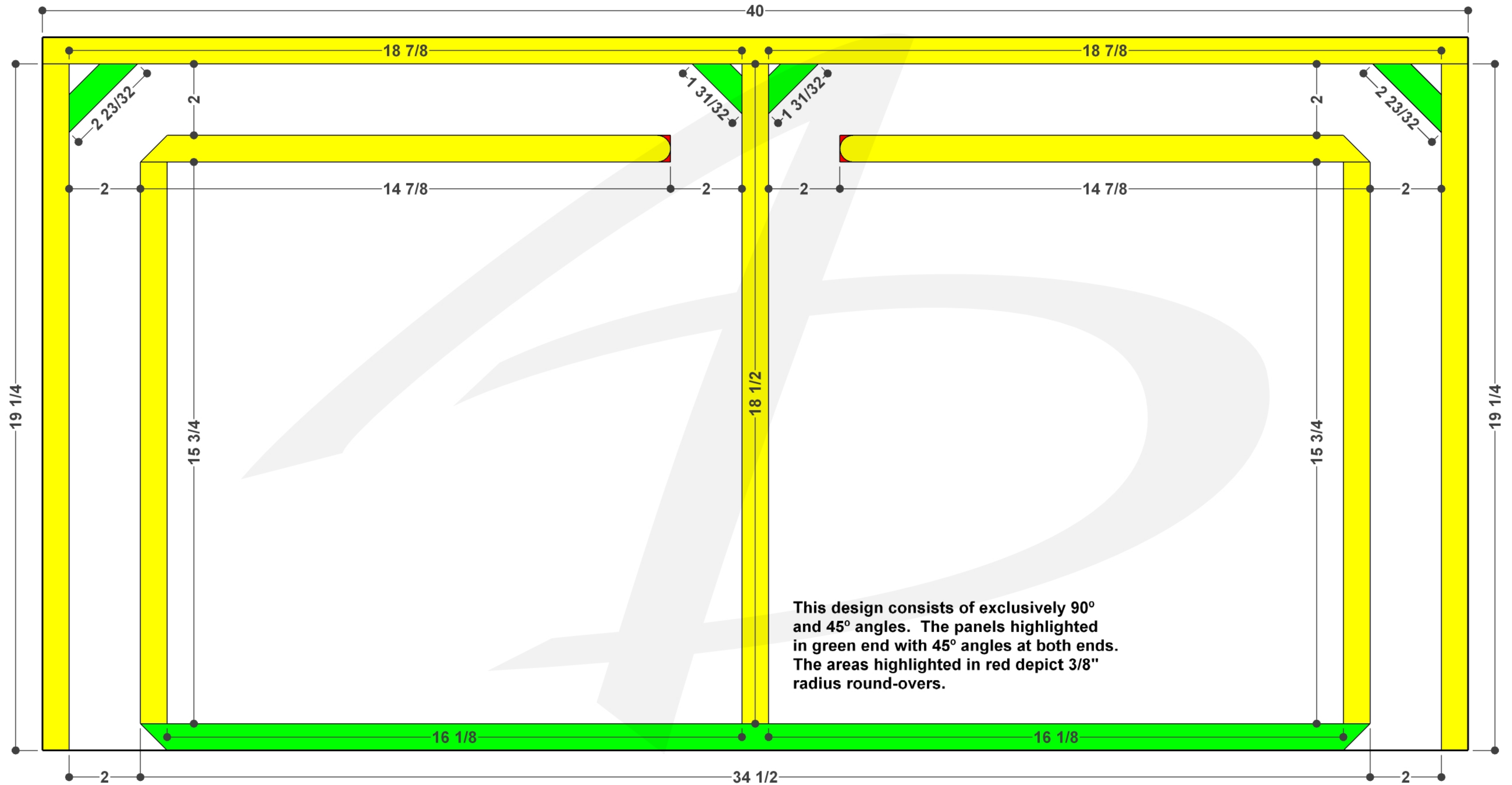

This design consists of exclusively 90° and 45° angles. The panels highlighted in green end with 45° angles at both ends. The areas highlighted in red depict 3/8" radius round-overs.

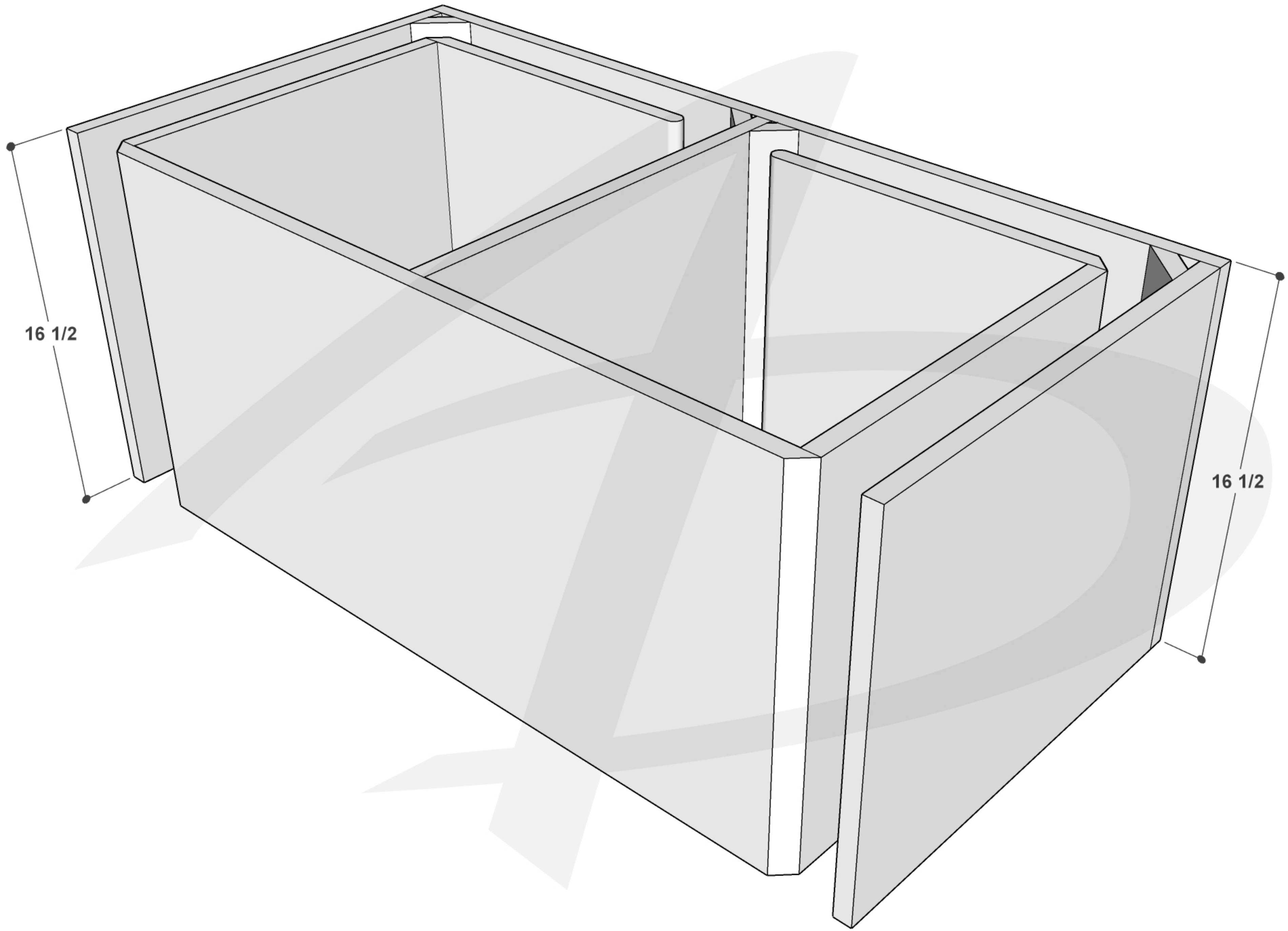

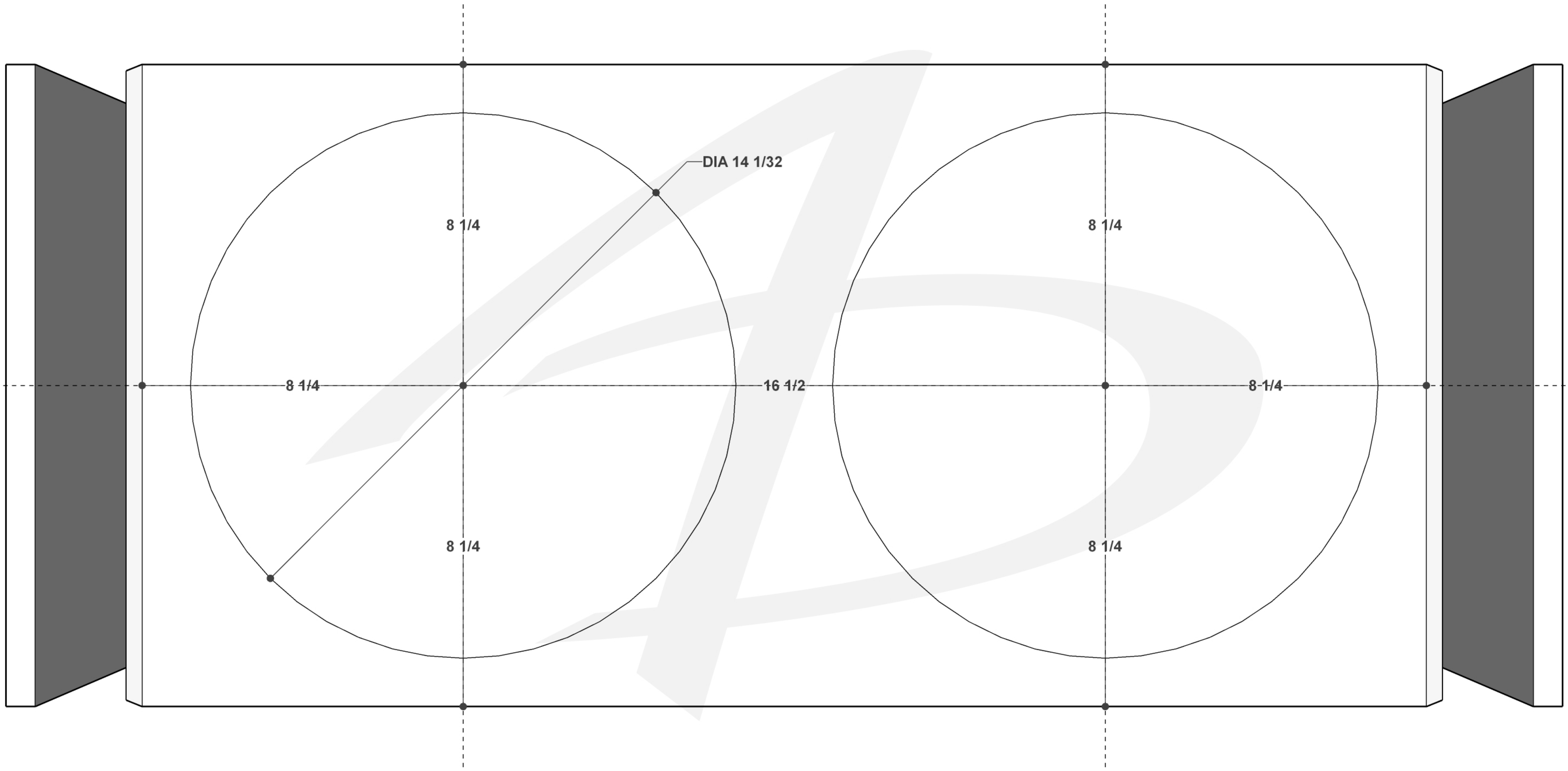

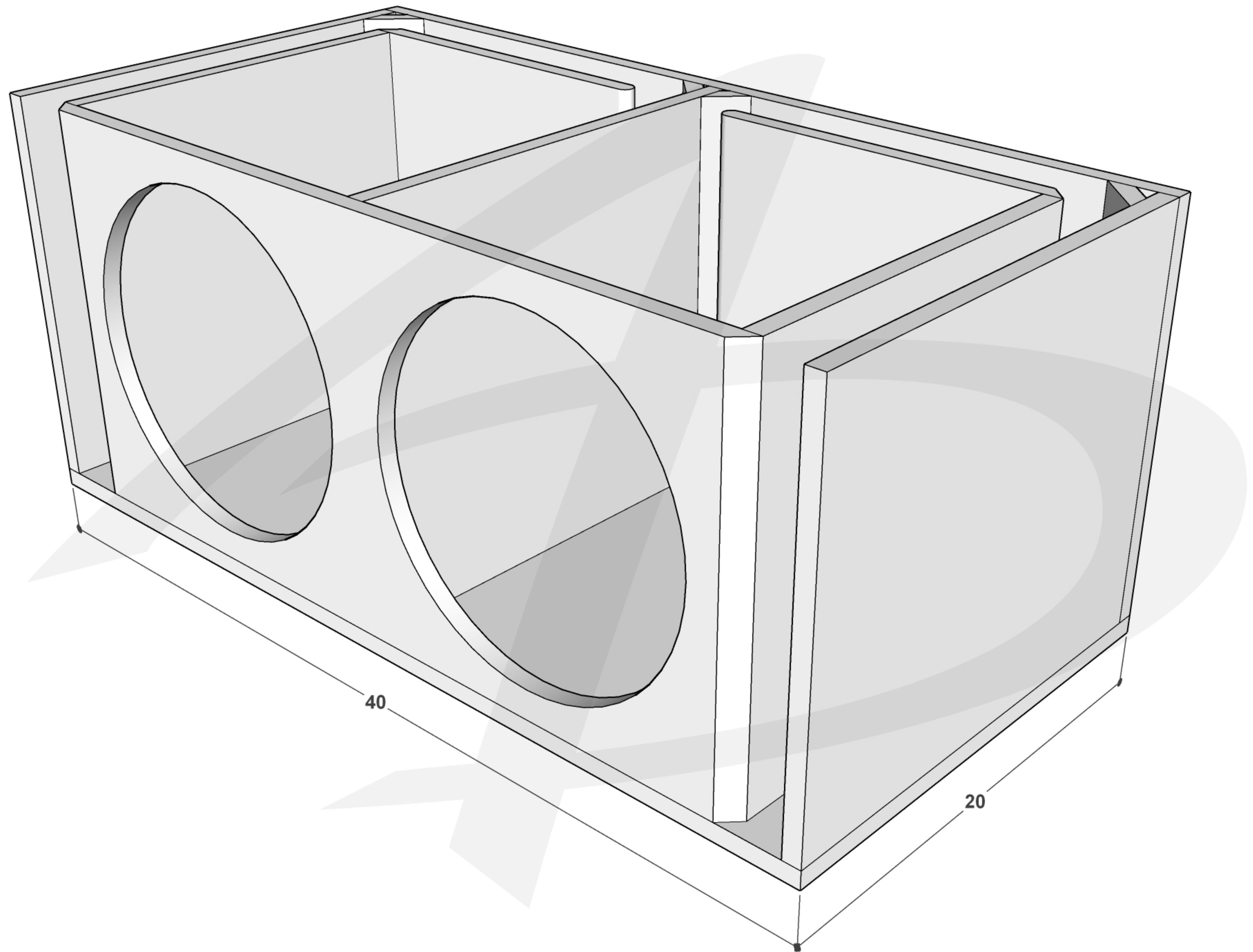

40

20

