

Vehicle Information	
Year	2005
Make	Honda
Model	Pilot

Enclosure Information	
Design Type	Bass-Reflex
Placement	Cargo area
Orientation	Position the enclosure with the subs directed rearward.



AUDIO DYNAMICS

Special Notes

Amplifier Information	
Continuous Power Handling	3,000 W
Subsonic Filter Setting	28 Hz
Low Pass Filter Setting	60 Hz

Subwoofer Information	
Make	Audio Dynamics
Model	AD5015 D4
Quantity	2

Performance Information	
SQ	<input checked="" type="checkbox"/> Within the Vehicle
<input checked="" type="checkbox"/> SQL	Outside the Vehicle
SPL	Metering Position

Metering Information		
Headrest	Peak Frequency	Hz
Dash / Windshield		
Foot Well		

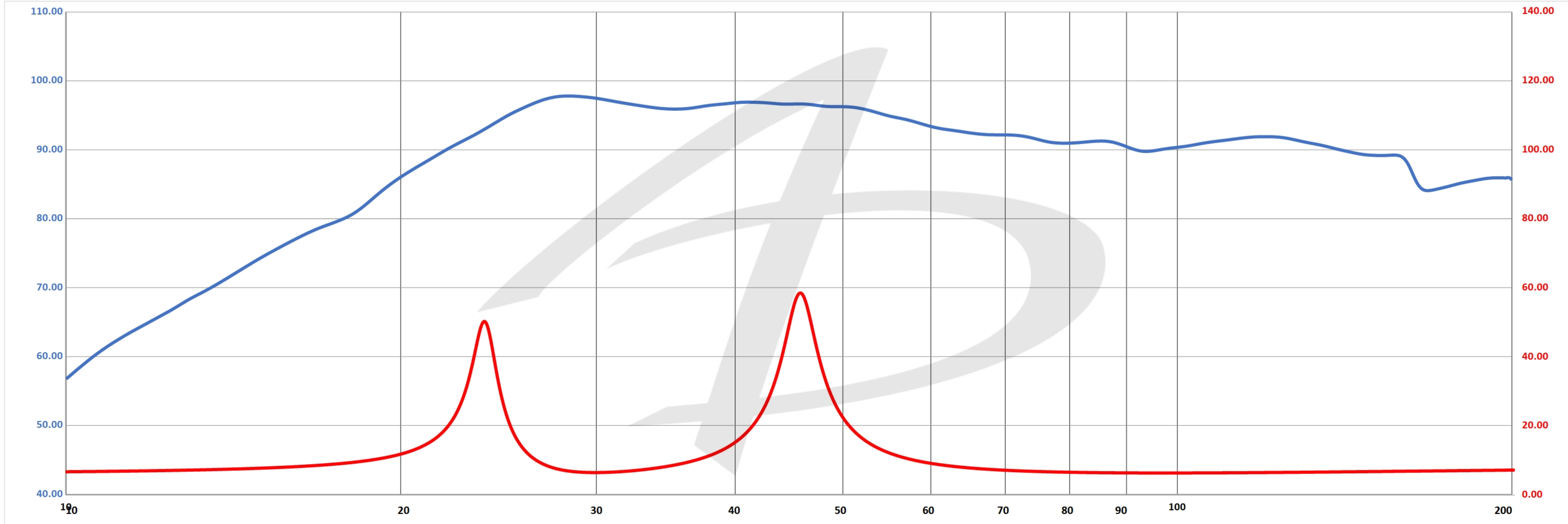

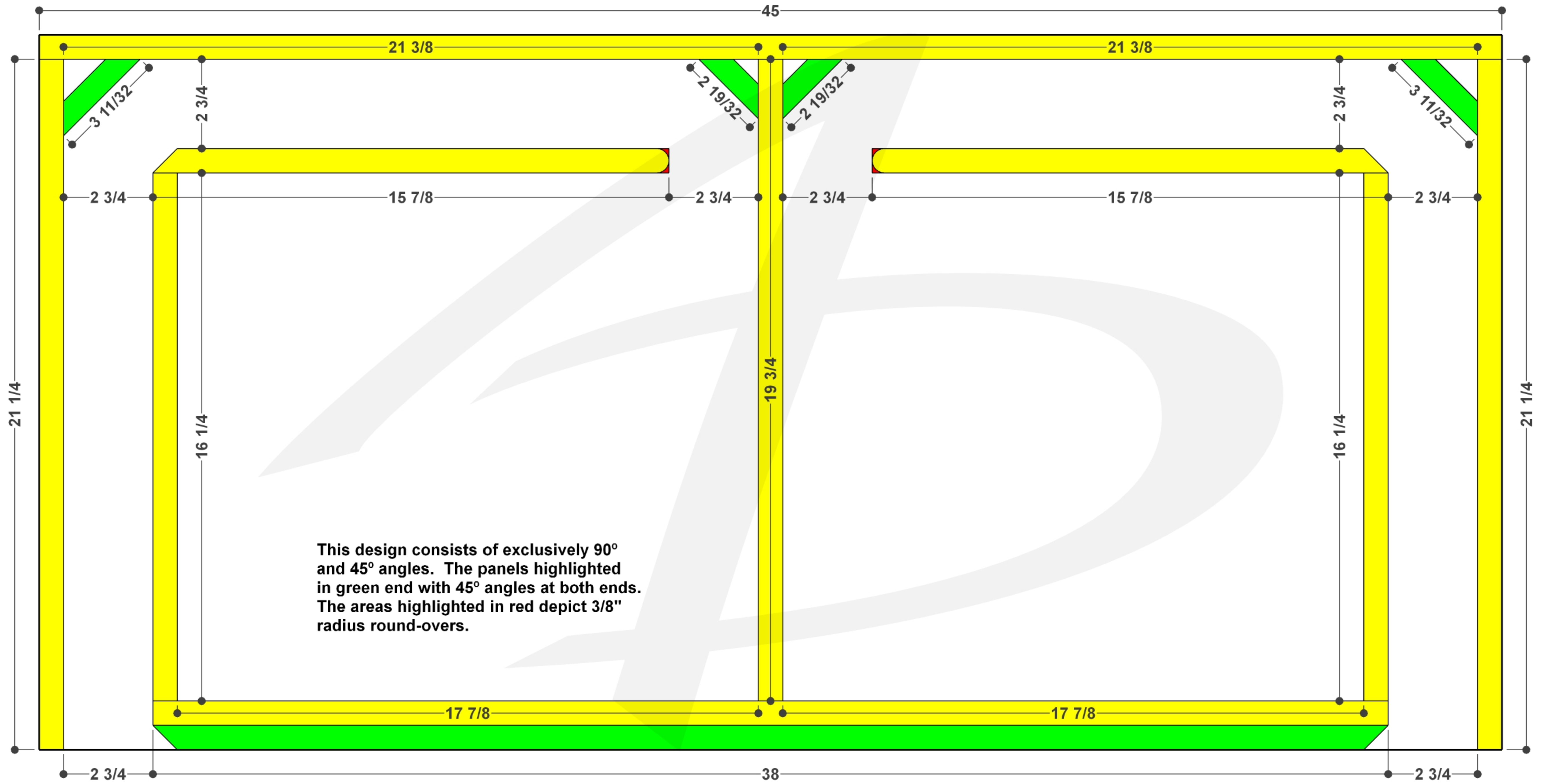

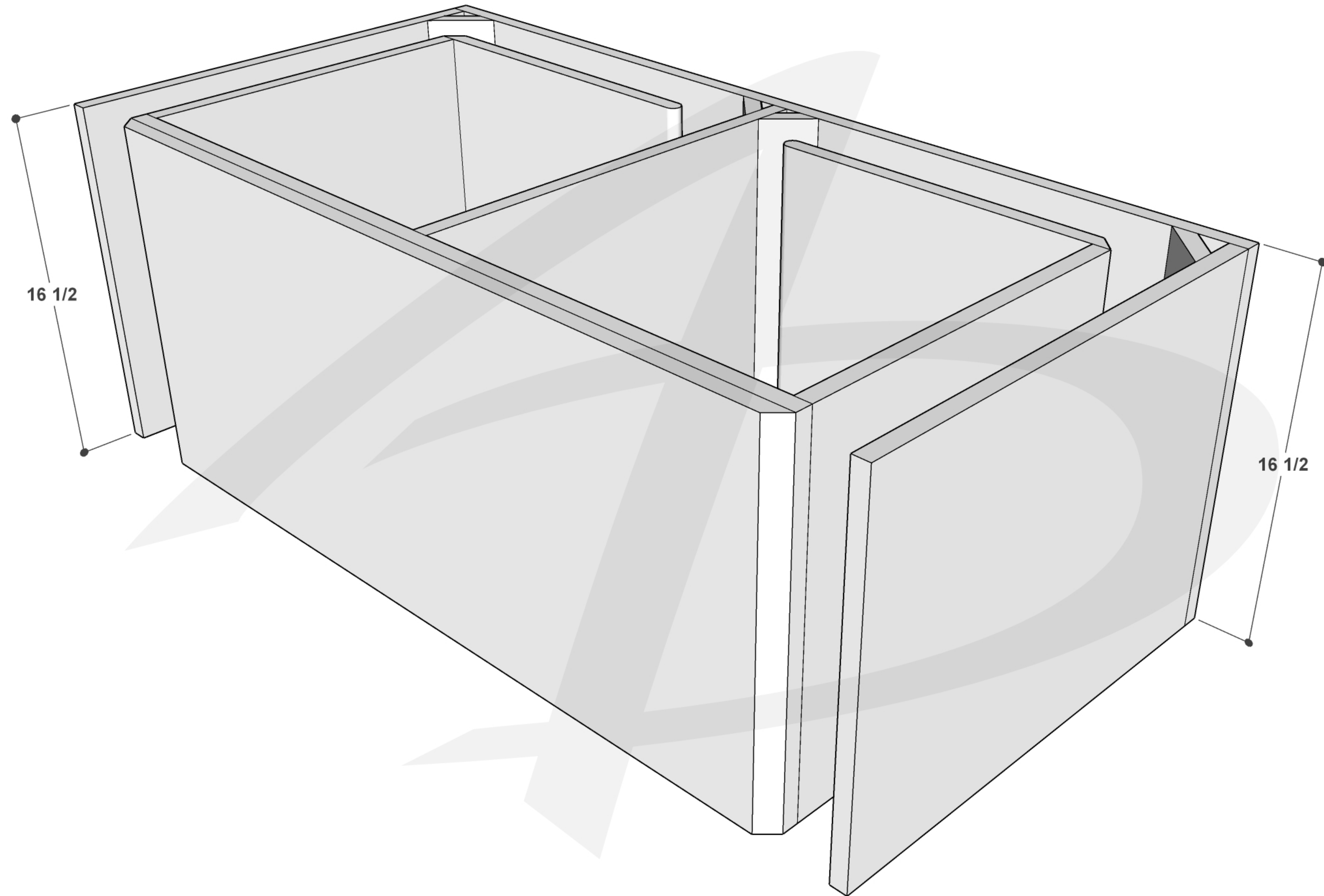

16 1/2

16 1/2

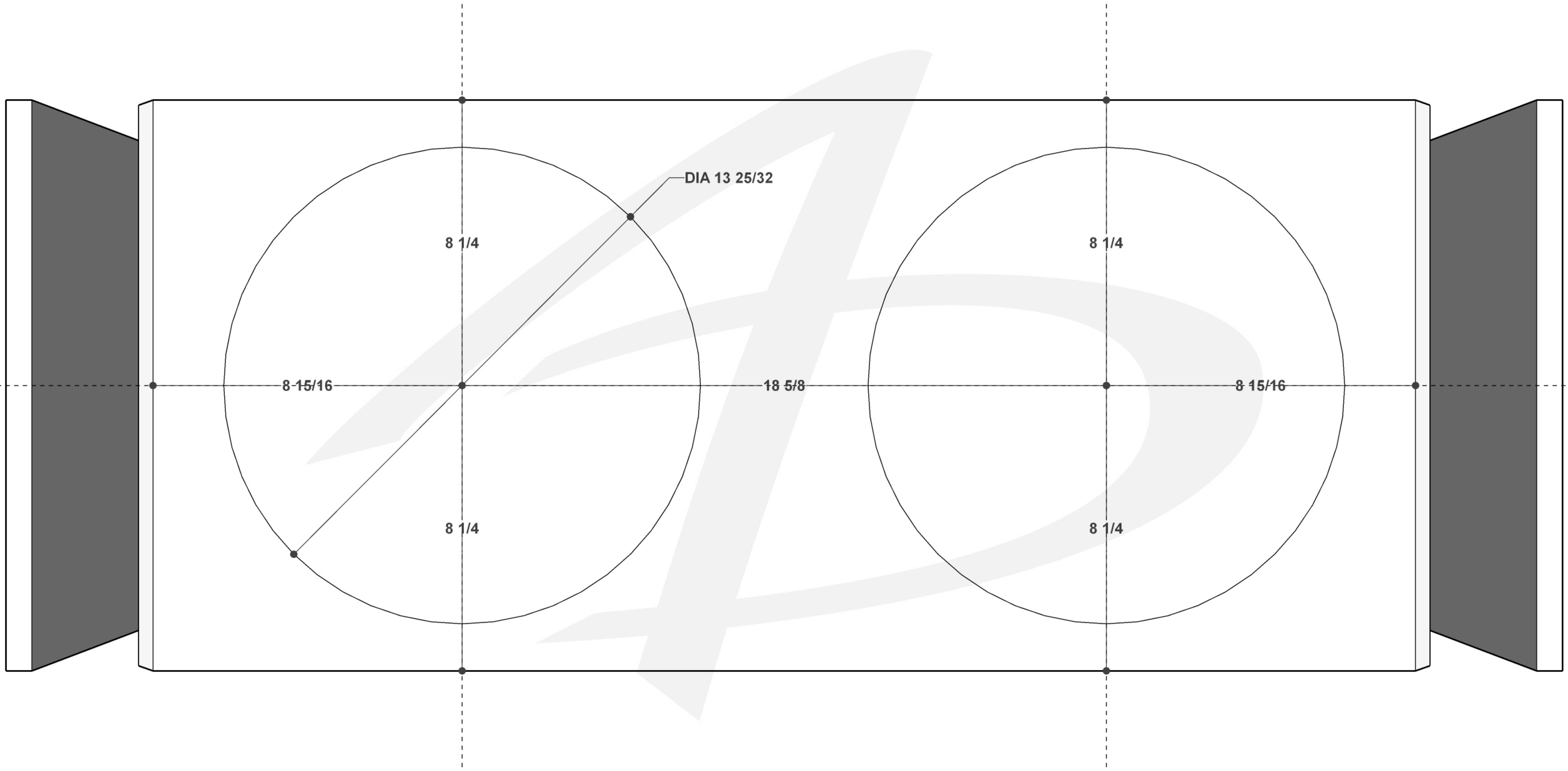

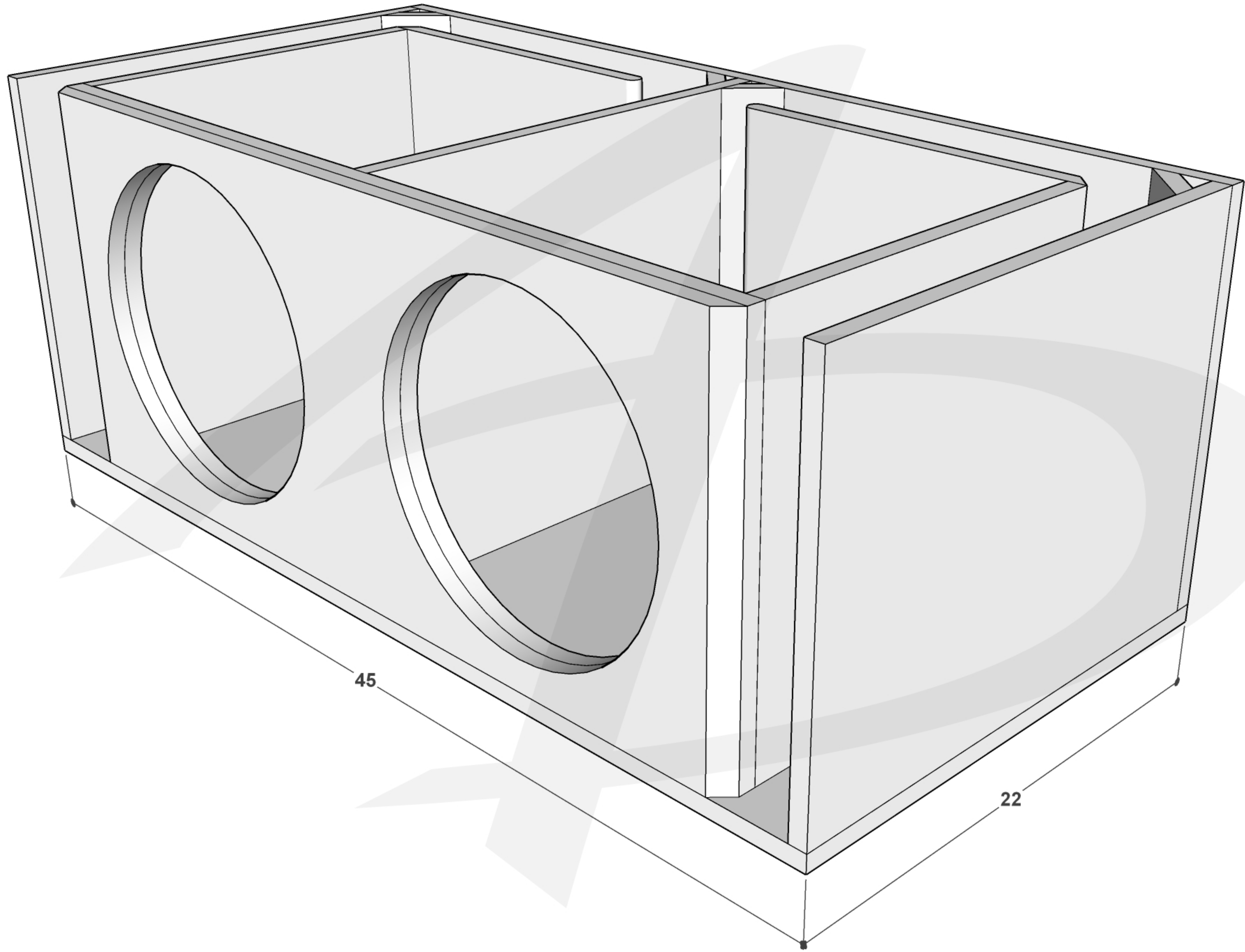

45

22

